



— MODEL — 90-ADJ-PRV-15

Field Adjustable Pressure Reducing Valve



- Sensitive and Accurate Pressure Restriction
- Easy Adjustment and Maintenance
- UL/ULC Listed

The Cla-Val 1 ½" Model 90-ADJ-PRV-15 features a Forged Brass finish body with Forgeline Bonnet and Seat Assembly. The system water pressure is controlled by adjusting the flow restriction, however, if full flow is required the restriction can be overridden.

This heavy duty design is factory tested to 300 psi (2070 KPa). It is also UL/ULC Listed.

A brass body is standard but can be supplied with a polish chrome, cast chrome or polish brass finish.

Specifications

Cla-Val Model 90-ADJ-PRV-15 UL/ULC Listed 300 lb. (2070 kPa) pressure tested standard angle hose valve where standpipe pressure on a hose rack assembly or as a fire department outlet connection is less than 90 psi (620 kPa).

Standards

NFPA 13 • Class II

NFPA 14 • Class II & III Standpipe Systems

Connections

FF = Female x Female • FM = Female x Male • GG = Groove x Groove • GM = Groove x Male

Automatic Sprinkler Systems

The 90-ADJ-PRV is listed by Underwriters Laboratories as a Special System Water Control Valve – Pressure Reducing and Pressure Control Type (VLMT), and also meets the listing requirements for indicating valves. Installation requirements of these pressure reducing valves in automatic sprinkler systems are defined in the Standard for Installation of Sprinkler Systems, NFPA 13. The 2.5" valve is listed for use in Class I and Class III systems; the 1.5" valve is listed for use in Class II systems. In addition, the 90-ADJ-PRV is also listed as a checking device, eliminating the need for a separate check valve.

Standpipe Installation Requirements

1. NFPA 14 requires that hose valve outlet pressure for Class I and Class III service be no greater than 175 psi and no less than 100 psi. When permitted by the authority having jurisdiction, pressures less than 100 psi may be allowed; discharge pressure shall not be less than 65 psig.
2. Class II hose valve must be limited to a maximum residual outlet pressure of 100 psi; discharge pressure shall not be less than 65 psig.
3. Upon completion of the system, each Cla-Val 90-ADJ-PRV valve shall be tested in accordance with the Standard for the Installation of Standpipe and Hose Systems, NFPA 14, to verify that the installation is correct, that the valves are operating properly, and that the inlet and outlet pressures at the valve are in accordance with the system design.

Dimensions

90-ADJ-PRV-15

Female x Female

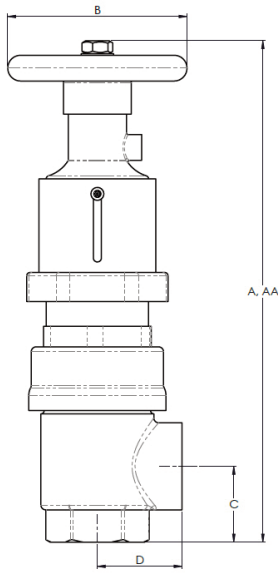

Female x Male

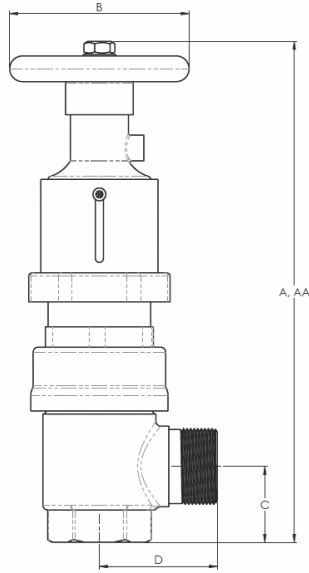

Groove x Groove

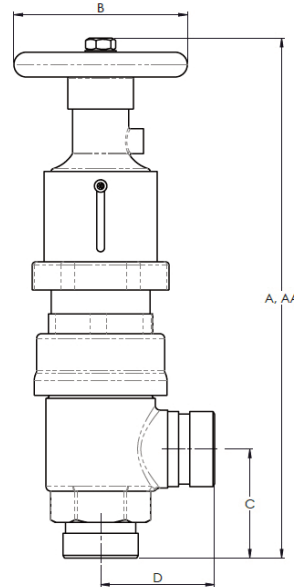

Groove x Male

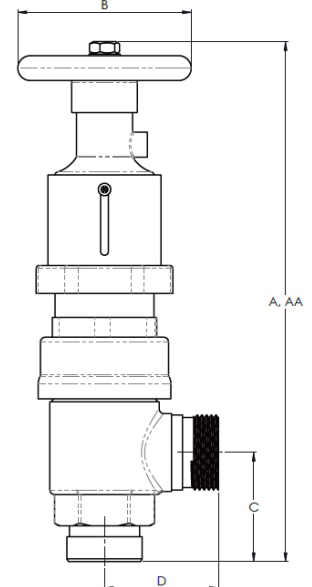

		A	AA	BØ	C	D
1.5 Adjustable Valve	Female x Female	11-3/4" (300.7)	12-1/4" (310.7)	4-1/2" (111.1)	1-3/4" (47)	2" (52.5)
	Female x Male	11-3/4" (300.7)	12-1/4" (310.7)	4-1/2" (111.1)	1-3/4" (47)	2-3/4" (73)
	Groove x Groove	12-3/4" (323.8)	13-1/4" (333.8)	4-1/2" (111.1)	2-3/4" (70)	2-3/4" (73)
	Groove x Male	12-3/4" (323.8)	13-1/4" (333.8)	4-1/2" (111.1)	2-3/4" (70)	2-3/4" (73)

90-ADJ-PRV-15 – With Switch

Female x Female

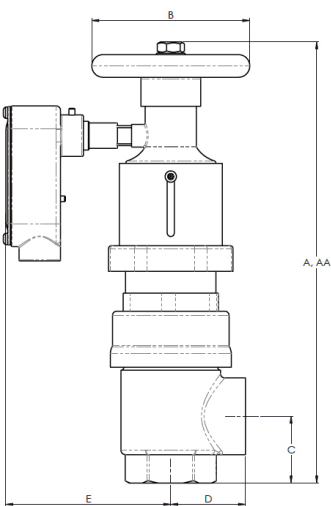

Female x Male

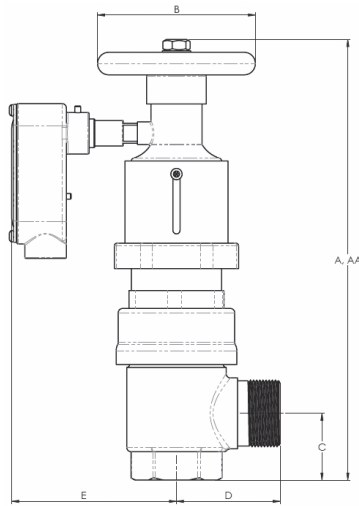

Groove x Groove

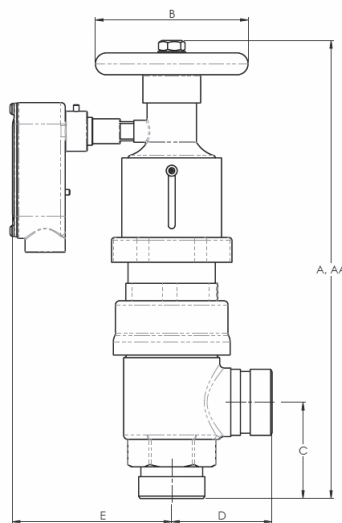

Groove x Male

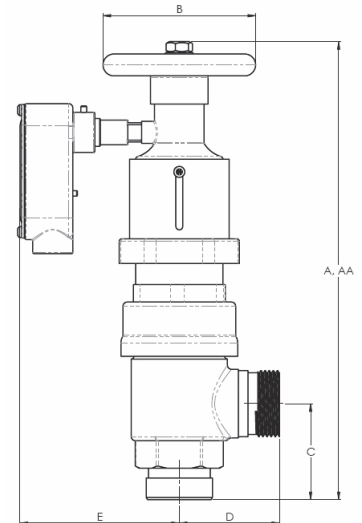

		A	AA	BØ	C	D	E
1.5 Adjustable Valve	Female x Female	11-3/4" (300.7)	12-1/4" (310.7)	4-1/2" (111.1)	1-3/4" (47)	2" (52.5)	4-1/2" (116)
	Female x Male	11-3/4" (300.7)	12-1/4" (310.7)	4-1/2" (111.1)	1-3/4" (47)	2-3/4" (73)	4-1/2" (116)
	Groove x Groove	12-3/4" (323.8)	13-1/4" (333.8)	4-1/2" (111.1)	2-3/4" (70)	2-3/4" (73)	4-1/2" (116)
	Groove x Male	12-3/4" (323.8)	13-1/4" (333.8)	4-1/2" (111.1)	2-3/4" (70)	2-3/4" (73)	4-1/2" (116)