



MODEL **133-01**
(Full Internal Port)
633-01
(Reduced Internal Port)

Metering Valve



- Automatically Measures and Controls Flow Rate Without a Separate Metering Device
- Completely Self Contained
- Reliable Analog Communications
- Retransmission Capabilities
- Ideal for Retrofitting Existing Valves
- Security System to Prevents Unauthorized Changes
- Optional Totalizing Capabilities

The Cla-Val Model 133-01/633-01 Metering Valve is a completely self contained valve and control system that accurately meters and/or controls flow rate when used on valves with pressure differentials of less than 100 psid.

Using a 131VC-3T Cla-Val Microprocessor, data from valve mounted differential pressure and position transmitters are assimilated into a proprietary algorithm program that is based on valve size and configuration to arrive at a flow measurement. This information is used for retransmission and/or compared with a local or remote set-point for valve flow control. The 133-01 Control System can also be installed on new or existing hydraulic pilot control valves such as: pressure reducing, pressure sustaining, flow limiting and level control to transmit flow rate without disturbing the valve's primary hydraulic function(s). Specify Kit 133-01 for these applications. Consult factory.

For all applications, specify voltage, minimum/maximum pressures and flow rates, valve size, pressure class and optional features. Consult your local representative or the Factory for engineering assistance and valve selection.

Schematic Diagram

Item	Description
1	Hytrol (Main Valve)
2	CS2S Solenoid Control
3	CK2 Solenoid By-Pass
4	DPT Differential Pressure Transmitter
5	131VC-3T Electronic Controller
6	X117D Position Transmitter
7	CK2 Isolation Valve

Optional Features

Item	Description
A	X46A Flow Clean Strainer
B	CK2 Isolation Valve
C	CV Flow Control (Closing)
D	Check Feature
F	Independent Operation Pressure
H	Atmospheric Drain
P	X141 Pressure Gauge
S	CV Flow Control (Opening)
Y	X43 "Y" Strainer

Please refer to the 131VC "Electronic Control Systems" brochure for specific information regarding valve theory of operation, standard and optional features, control parameters and electrical component specifications.

Typical Applications

The Model 133-01/633-01 Metering and Flow Rate Controller is typically installed in a fluid delivery system where the flow rate is measured and changed from a remote location such as a SCADA system.

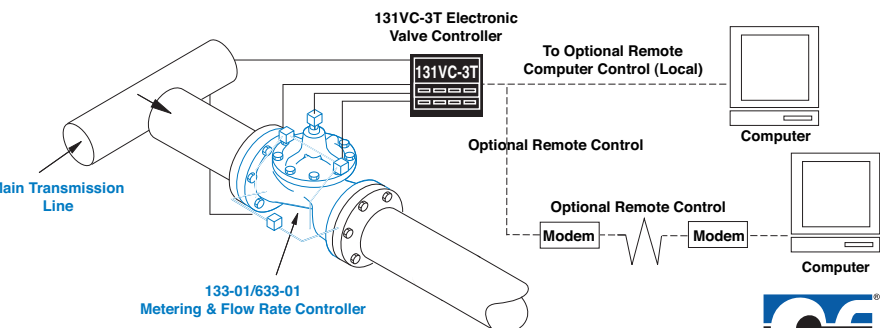
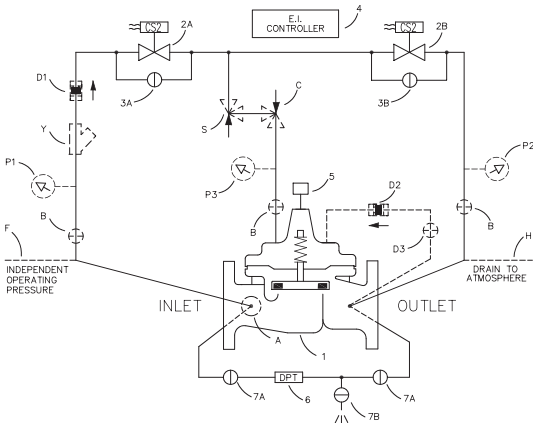

Model 133-01 (Uses Basic Valve Model 100-01)

Pressure Ratings (Recommended Maximum Pressure - psi)

Valve Body & Cover		Pressure Class				
		Flanged		Grooved	Threaded	
Grade	Material	ANSI Standards*	150 Class	300 Class	300 Class	End‡ Details
ASTM A536	Ductile Iron	B16.42	250	400	400	400
ASTM A216-WCB	Cast Steel	B16.5	285	400	400	400
ASTM B62	Bronze	B16.24	225	400	400	400

Note: * ANSI standards are for flange dimensions only.
 Flanged valves are available faced but not drilled.
 ‡ End Details machined to ANSI B2.1 specifications.
Valves for higher pressure are available; consult factory for details

Materials

Component	Standard Material Combinations		
Body & Cover	Ductile Iron	Cast Steel	Bronze
Available Sizes	3" - 36"	3" - 16"	3" - 16"
Disc Retainer & Diaphragm Washer	Cast Iron	Cast Steel	Bronze
Trim: Disc Guide, Seat & Cover Bearing	Bronze is Standard Stainless Steel is Optional		
Disc	Buna-N® Rubber		
Diaphragm	Nylon Reinforced Buna-N® Rubber		
Stem, Nut & Spring	Stainless Steel		

For material options not listed, consult factory.
 Cla-Val manufactures valves in more than 50 different alloys.

Dimensions
(In inches)

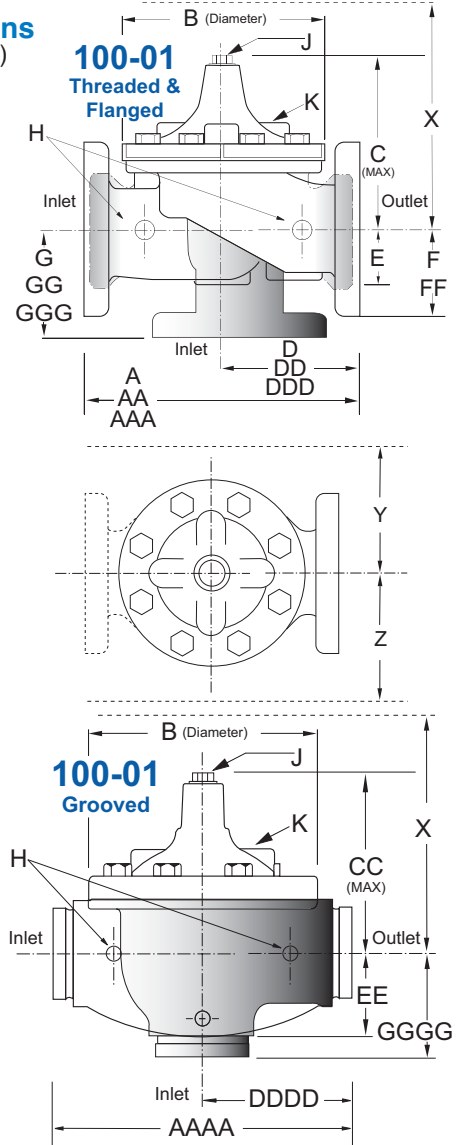

Model 133-01 Dimensions (In Inches)

Valve Size (Inches)	3	4	6	8	10	12	14	16	18	20	24	30	36
A Threaded	12.50	—	—	—	—	—	—	—	—	—	—	—	—
AA 150 ANSI	12.00	15.00	20.00	25.38	29.75	34.00	39.00	41.38	46.00	52.00	61.50	63.00	76.00
AAA 300 ANSI	13.25	15.62	21.00	26.38	31.12	35.50	40.50	43.50	47.64	53.62	63.24	64.50	76.00
AAAA Grooved End	12.50	15.00	20.00	25.38	—	—	—	—	—	—	—	—	—
B Dia.	9.12	11.50	15.75	20.00	23.62	28.00	32.75	35.50	41.50	45.00	53.16	56.00	66.00
C Max.	8.19	10.62	13.38	16.00	17.12	20.88	24.19	25.00	39.06	41.90	43.93	54.60	61.50
CC Max. Grooved End	7.25	9.31	12.12	14.62	—	—	—	—	—	—	—	—	—
D Threaded	6.25	—	—	—	—	—	—	—	—	—	—	—	—
DD 150 ANSI	6.00	7.50	10.00	12.69	14.88	17.00	19.50	20.81	—	—	30.75	—	—
DDD 300 ANSI	6.38	7.88	10.50	13.25	15.56	17.75	20.25	21.62	—	—	31.62	—	—
DDDD Grooved End	6.00	7.50	—	—	—	—	—	—	—	—	—	—	—
E	2.06	3.19	4.31	5.31	9.25	10.75	12.62	15.50	12.95	15.00	17.75	21.31	24.56
EE Grooved End	3.12	4.25	6.00	7.56	—	—	—	—	—	—	—	—	—
F 150 ANSI	3.75	4.50	5.50	6.75	8.00	9.50	10.50	11.75	15.00	16.50	19.25	22.50	25.60
FF 300 ANSI	4.13	5.00	6.25	7.50	8.75	10.25	11.50	12.75	15.00	16.50	19.25	24.00	25.60
G Threaded	4.50	—	—	—	—	—	—	—	—	—	—	—	—
GG 150 ANSI	4.00	5.00	6.00	8.00	8.62	13.75	14.88	15.69	—	—	22.06	—	—
GGG 300 ANSI	4.38	5.31	6.50	8.50	9.31	14.50	15.62	16.50	—	—	22.90	—	—
GGGG Grooved End	4.25	5.00	—	—	—	—	—	—	—	—	—	—	—
H NPT Body Tapping	.50	.75	.75	1	1	1	1	1	1	1	1	2	2
J NPT Cover Center Plug	.50	.75	.75	1	1	1.25	1.5	2	1.5	1.5	1.5	2	2
K NPT Cover Tapping	.50	.75	.75	1	1	1	1	1	1	1	1	2	2
Stem Travel	0.8	1.1	1.7	2.3	2.8	3.4	4.0	4.5	5.1	5.63	6.75	7.5	8.5
Approx. Ship Wt. Lbs.	70	140	285	500	780	1165	1600	2265	2982	3900	6200	7703	11720
X Pilot System	15	17	29	31	33	36	40	40	43	47	68	79	85
Y Pilot System	11	12	20	22	24	26	29	30	32	34	39	40	45
Z Pilot System	11	12	20	22	24	26	29	30	32	34	39	42	47

Note: The top two flange holes on valve size 36 are threaded to 1 1/2"-6 UNC.

Model 633-01 (Uses Basic Valve Model 100-20)

Dimensions
(In inches)

Pressure Ratings (Recommended Maximum Pressure - psi)

Valve Body & Cover		Pressure Class		
		Flanged		
Grade	Material	ANSI Standards*	150 Class	300 Class
ASTM A536	Ductile Iron	B16.42	250	400
ASTM A216-WCB	Cast Steel	B16.5	285	400
ASTM B62	Bronze	B16.24	225	400

Note: * ANSI standards are for flange dimensions only.
Flanged valves are available faced but not drilled.
Valves for higher pressure are available; consult factory for details

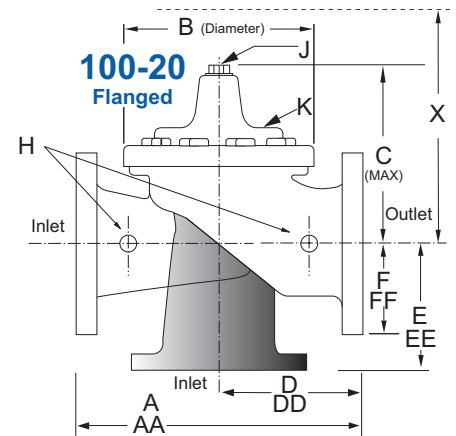

Materials

Component	Standard Material Combinations		
Body & Cover	Ductile Iron	Cast Steel	Bronze
Available Sizes	3" - 48"	3" - 16"	3" - 16"
Disc Retainer & Diaphragm Washer	Cast Iron	Cast Steel	Bronze
Trim: Disc Guide, Seat & Cover Bearing	Bronze is Standard Stainless Steel is Optional		
Disc	Buna-N® Rubber		
Diaphragm	Nylon Reinforced Buna-N® Rubber		
Stem, Nut & Spring	Stainless Steel		

For material options not listed, consult factory.
Cla-Val manufactures valves in more than 50 different alloys.

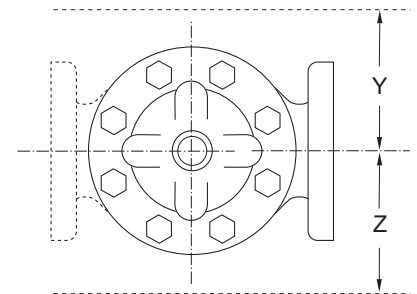

Model 633-01 Dimensions (In Inches)

Valve Size (Inches)	3	4	6	8	10	12	14	16	18	20	24	30	36	42	48
A 150 ANSI	10.25	13.88	17.75	21.38	26.00	30.00	34.25	35.00	42.12	48.00	48.00	63.25	65.00	76.00	94.50
AA 300 ANSI	11.00	14.50	18.62	22.38	27.38	31.50	35.75	36.62	43.63	49.62	49.75	63.75	67.00	76.00	94.50
B Dia.	6.62	9.12	11.50	15.75	20.00	23.62	27.47	28.00	35.44	35.44	35.44	53.19	56.00	66.00	66.00
C Max.	7.00	8.62	11.62	15.00	17.88	21.00	20.88	25.75	25.00	31.00	31.00	43.94	54.60	61.50	61.50
D 150 ANSI	—	6.94	8.88	10.69	CF*	CF*	CF*	CF*	CF*	CF*	CF*	—	—	—	—
DD 300 ANSI	—	7.25	9.38	11.19	CF*	CF*	CF*	CF*	CF*	CF*	CF*	—	—	—	—
E 150 ANSI	—	5.50	6.75	7.25	CF*	CF*	CF*	CF*	CF*	CF*	CF*	—	—	—	—
EE 300 ANSI	—	5.81	7.25	7.75	CF*	CF*	CF*	CF*	CF*	CF*	CF*	—	—	—	—
F 150 ANSI	3.75	4.50	5.50	6.75	8.00	9.50	11.00	11.75	15.88	14.56	17.00	19.88	25.50	28.00	31.50
FF 300 ANSI	4.12	5.00	6.25	7.50	8.75	10.25	11.50	12.75	15.88	16.06	19.00	22.00	27.50	28.00	31.50
H NPT Body Tapping	.375	.50	.75	.75	1	1	1	1	1	1	1	1	2	2	2
J NPT Cover Center Plug	.50	.50	.75	.75	1	1	1.25	1.25	2	2	2	2	2	2	2
K NPT Cover Tapping	.375	.50	.75	.75	1	1	1	1	1	1	1	1	2	2	2
Stem Travel	0.6	0.8	1.1	1.7	2.3	2.8	3.4	3.4	3.4	4.5	4.5	6.5	7.5	8.5	8.5
Approx. Ship Wt. Lbs.	45	85	195	330	625	900	1250	1380	1500	2551	2733	6500	8545	12450	13100
X Pilot System	13	15	27	30	33	36	36	41	40	46	55	68	79	85	86
Y Pilot System	10	11	18	20	22	24	26	26	30	30	30	39	40	45	47
Z Pilot System	10	11	18	20	22	24	26	26	30	30	30	39	42	47	49

*Consult Factory

Note: The top two flange holes on valve sizes 36 thru 48 are threaded to 1 1/2"-6 UNC.

133-01 Valve Selection	100-01 Pattern: Globe (G), Angle (A), End Connections: Threaded (T), Grooved (GR), Flanged (F) Indicate Available Sizes													
	Inches	3	4	6	8	10	12	14	16	18	20	24	30	36
	mm	80	100	150	200	250	300	350	400	450	500	600	750	900
Basic Valve 100-01	Pattern	G, A	G, A	G, A	G, A	G, A	G, A	G, A	G, A	G	G	G, A	G	G
	End Detail	T, F, Gr	F, Gr	F, Gr*	F, Gr*	F	F	F	F	F	F	F	F	F
Suggested Flow (gpm)	Maximum	460	800	1800	3100	4900	7000	8400	11000	14000	17000	25000	42000	50000
	Maximum Intermittent	580	990	2250	3900	6150	8720	10540	13700	17500	21700	31300	48000	62500
Suggested Flow (Liters/Sec)	Maximum	29	50	113	195	309	442	530	694	883	1073	1577	2650	3150
	Maximum Intermittent	37	62	142	246	387	549	664	863	1104	1369	1972	3028	3940
100-01 Series is the full internal port Hytrol.												*Globe Grooved Only		

633-01 Valve Selection	100-20 Pattern: Globe (G), Angle (A), End Connections: Flanged (F) Indicate Available Sizes															
	Inches	3	4	6	8	10	12	14	16	18	20	24	30	36	42	48
	mm	80	100	150	200	250	300	350	400	450	500	600	750	900	1000	1200
Basic Valve 100-20	Pattern	G	G, A	G, A	G, A	G	G	G	G	G	G	G	G	G	G	G
	End Detail	F	F	F	F	F	F	F	F	F	F	F	F	F	F	F
Suggested Flow (gpm)	Maximum	260	580	1025	2300	4100	6400	9230	9230	16500	16500	16500	28000	33500	33500	33500
Suggested Flow (Liters/Sec)	Maximum	16	37	65	145	258	403	581	581	1040	1040	1040	1764	2115	2115	2115
100-20 Series is the reduced internal port size version of the 100-01 Series.																
We recommend providing adequate space around valve for maintenance work																

Pilot System Specifications*

Temperature Range

Water: to 180°F

Voltage:

24, 120, 240, 480 - 60Hz AC
24 - DC

Rubber Parts:

Buna-N® Rubber Synthetic

Max. operating pressure differential:
100 psi

Solenoid Control

Body: Brass ASTM B283

Coil:

Enclosure: NEMA Type 1,2,3,3S,4,4X general
purpose watertight
NEMA Type 6,6P,7,9 watertight
explosion proof available

Insulation Molded Class	F
Watts AC	6
AC Volt Amps Inrush	30
AC Volt Amps Holding	16
Watts DC	10.6

When Ordering, Please Specify

1. Catalog No. 133-01 or No. 633-01
2. Valve Size
3. Pattern - Globe or Angle
4. Pressure Class
5. Threaded or Flanged
6. Trim Material
7. Electrical Specifications
8. Desired Options
9. When Vertically Installed

*For specifications on other 133/633 Series Valves, please consult factory. The 133-01/633-01 is shown.