

CLA-VAL

AUTOMATIC CONTROL VALVES

129-01/629-01

Place this manual with personal responsible
for maintenance of this valve

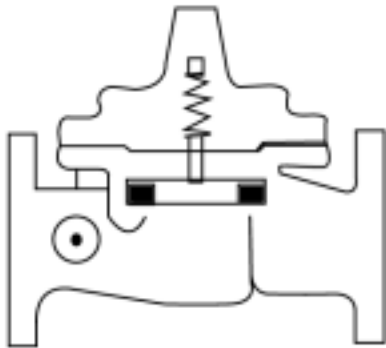

INSTALLATION

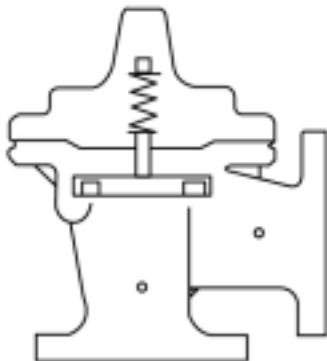

OPERATION

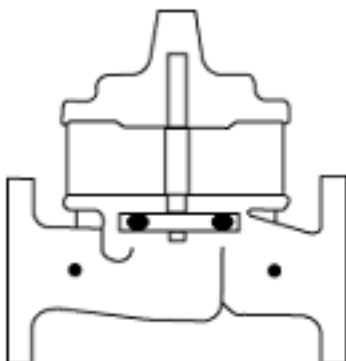

MAINTENANCE





NEWPORT BEACH, CALIFORNIA

CATALOG NO.
129-01/629-01

DRAWING NO.
90490

REV.
B

TYPE OF VALVE AND MAIN FEATURES

MODULATING FLOAT VALVE

DESIGN		
DRAW	CH	8-22-75
CHK'D	MF	9-5-75
AP'VD	JAW	9-9-75

----- NOT FURNISHED BY CLA-VAL CO. ----- OPTIONAL FEATURES

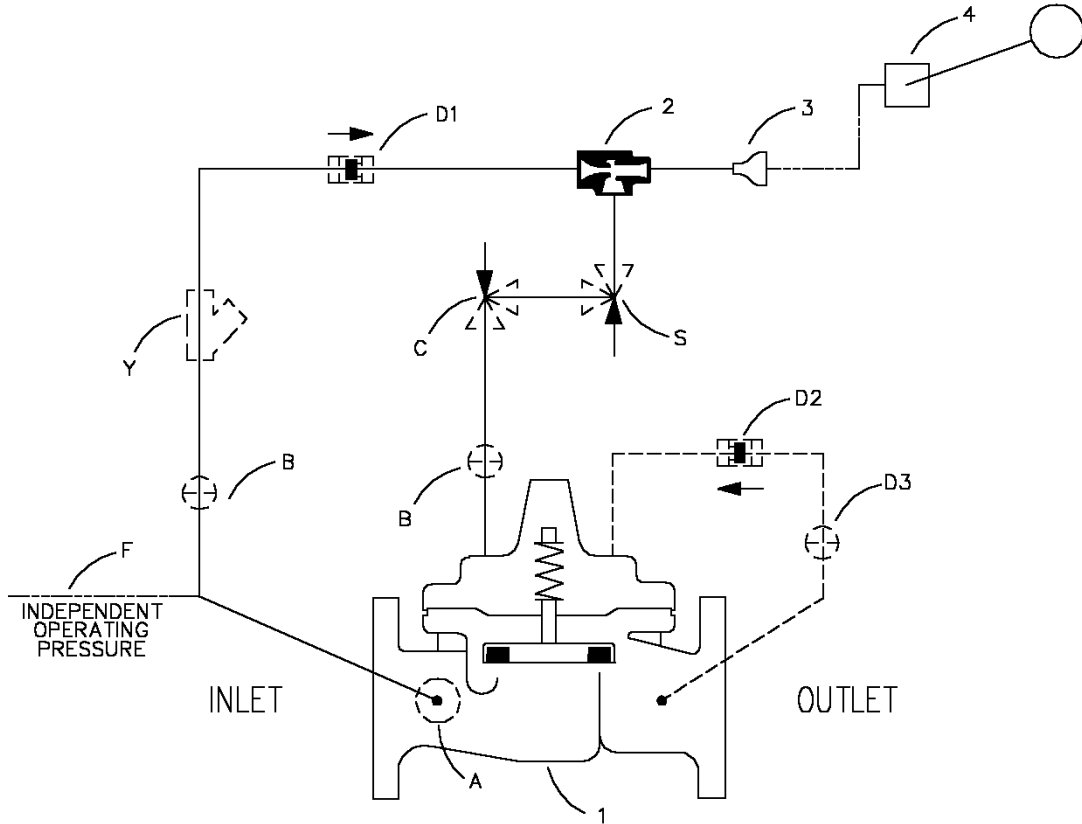

ITEM NO.	BASIC COMPONENTS	QTY
1	100-01 HYTROL (129-01) MAIN VALVE	1
	100-20 HYTROL (629-01) MAIN VALVE	
2	X47A EJECTOR	1
3	BELL REDUCER	1
4	CFM2 FLOAT CONTROL	1

OPTIONAL FEATURE SUFFIX		ADDED TO CATALOG NUMBER	
A	X46A FLOW CLEAN STRAINER	1	Y X43 "Y" STRAINER
B	CK2 COCK (ISOLATION VALVE)	2	
C	CV FLOW CONTROL (CLOSING)	1	
D	CHECK VALVES WITH COCK	1	
F	INDEPENDENT OPERATING PRESSURE	1	
S	CV FLOW CONTROL (OPENING)	1	

6-3-93
 11-19-93
 ON CAD (ECO 13808)
 X47A EJECTOR WAS SHOWN BACKWARDS. (ECO 14263)
 B
 DATE
 BY
 CAD REVISION RECORD - DO NOT REVISE MANUALLY
 DESCRIPTION
 A ADDED 100-20 (629-01) TO ITEM 1 & "D" FEATURE;
 REMOVED "J" FEATURE; CAT NO. WAS 129-01 & REDRAWN
 LTR

THIS DRAWING IS THE PROPERTY OF CLA-VAL CO. AND SAME AND COPIES MADE THEREOF, IF ANY, SHALL BE RETURNED TO IT UPON DEMAND. DELIVERY AND DISCLOSURE HEREOF ARE SOLELY UPON CONDITION THAT THE SAME SHALL NOT BE USED, COPIED OR REPRODUCED, NOR SHALL THE SUBJECT HEREOF BE DISCLOSED IN ANY MANNER TO ANYONE FOR ANY PURPOSE, EXCEPT AS HEREIN AUTHORIZED, WITHOUT PRIOR WRITTEN APPROVAL OF CLA-VAL CO. THIS DRAWING IS SUBMITTED CONFIDENTIALLY AND MAY NOT BE USED IN THE MANUFACTURE OF ANY MATERIAL OR PRODUCT OTHER THAN SUCH MATERIALS AND PRODUCTS FURNISHED TO CLA-VAL CO. WHETHER OR NOT THE EQUIPMENT OR INFORMATION SHOWN HEREON IS PATENTED OR OTHERWISE PROTECTED, FULL TITLE AND COPYRIGHTS, IF ANY, IN AND TO THIS DRAWING AND/OR INFORMATION DELIVERED OR SUBMITTED ARE FULLY RESERVED CLA-VAL CO.®



CLA-VAL CO.

NEWPORT BEACH, CALIFORNIA

CATALOG NO.
129-01/629-01

DRAWING NO.
90490

REV.
B

TYPE OF VALVE AND MAIN FEATURES

MODULATING FLOAT VALVE

DESIGN		
DRAW	CH	8-22-75
CHK'D	MF	9-5-75
AP'VD	JAW	9-9-75

OPERATING DATA

I. MODULATING FLOAT VALVE FEATURE:

FLOW THROUGH CONTROL (4) VARIES IN RESPONSE TO THE SLIGHT LIQUID LEVEL CHANGES. RISING LIQUID LEVEL (FLOAT BALL UP) TENDS TO CLOSE THE MAIN VALVE (1), AND LOWERING LIQUID LEVEL (FLOAT BALL DOWN) TENDS TO OPEN THE MAIN VALVE. WHEN THE FLOAT BALL RISES TO THE TOP POSITION, ALL FLOW THROUGH FLOAT CONTROL (4) IS BLOCKED AND THE MAIN VALVE CLOSES.

II. OPTIONAL FEATURE OPERATING DATA:

SUFFIX A (FLOW CLEAN STRAINER)

A SELF-CLEANING STRAINER IS INSTALLED IN THE MAIN VALVE INLET BODY BOSS WHICH PROTECTS THE PILOT SYSTEM FROM FOREIGN PARTICLES.

SUFFIX B (ISOLATION VALVES)

CK2 COCKS (B) ARE USED TO ISOLATE THE PILOT SYSTEM FROM MAIN LINE PRESSURE. THESE VALVES MUST BE OPEN DURING NORMAL OPERATION.

SUFFIX C (CLOSING SPEED CONTROL)

FLOW CONTROL (C) CONTROLS THE CLOSING SPEED OF THE MAIN VALVE. TURN THE ADJUSTING STEM CLOCKWISE TO MAKE THE MAIN VALVE CLOSE

SUFFIX D (CHECK VALVES WITH COCK)

WHEN OUTLET PRESSURE IS HIGHER THAN INLET PRESSURE, CHECK VALVE (D2) OPENS AND (D1) CLOSES. THIS DIRECTS THE HIGHER OUTLET PRESSURE INTO THE MAIN VALVE COVER AND THE MAIN VALVE CLOSES.

SUFFIX F (INDEPENDENT OPERATING PRESSURE)

PILOT SUPPLY PRESSURE IS OBTAINED FROM AN INDEPENDENT SOURCE. (PILOT SUPPLY PRESSURE IS OBTAINED FROM THE MAIN VALVE INLET IF SUFFIX (F) IS NOT SPECIFIED.) NOTE: INDEPENDENT OPERATING PRESSURE MUST BE EQUAL TO OR GREATER THAN PRESSURE AT THE MAIN VALVE INLET AT ALL TIMES.

SUFFIX S (OPENING SPEED CONTROL)

NEEDLE VALVE (S) CONTROLS THE OPENING SPEED OF THE MAIN VALVE. TURN THE ADJUSTING STEM CLOCKWISE TO MAKE THE MAIN VALVE OPEN SLOWER. DO NOT CLOSE VALVE (S) COMPLETELY OR MAIN VALVE WILL NOT OPEN. SUGGESTED INITIAL SETTING 1/4 TURN OPEN.

SUFFIX Y (Y-STRAINER)

A Y-PATTERN STRAINER IS INSTALLED IN THE PILOT SUPPLY LINE TO PROTECT THE PILOT SYSTEM FROM FOREIGN PARTICLES. THE STRAINER SCREEN MUST BE CLEANED PERIODICALLY.

CAD REVISION RECORD - DO NOT REVISE MANUALLY

DATE	
BY	
DESCRIPTION	
SEE SHEET 1	
LTR	

THIS DRAWING IS THE PROPERTY OF CLA-VAL CO. AND SAME AND COPIES MADE THEREOF, IF ANY, SHALL BE RETURNED TO IT UPON DEMAND. DELIVERY AND DISCLOSURE HEREOF ARE SOLELY UPON CONDITION THAT THE SAME SHALL NOT BE USED, COPIED OR REPRODUCED, NOR SHALL THE SUBJECT HEREOF BE DISCLOSED IN ANY MANNER TO ANYONE FOR ANY PURPOSE, EXCEPT AS HEREIN AUTHORIZED, WITHOUT PRIOR WRITTEN APPROVAL OF CLA-VAL CO. THIS DRAWING IS SUBMITTED CONFIDENTIALLY AND MAY NOT BE USED IN THE MANUFACTURE OF ANY MATERIAL OR PRODUCT OTHER THAN SUCH MATERIALS AND PRODUCTS FURNISHED TO CLA-VAL CO. WHETHER OR NOT THE EQUIPMENT OR INFORMATION SHOWN HEREON IS PATENTED OR OTHERWISE PROTECTED, FULL TITLE AND COPYRIGHTS, IF ANY, IN AND TO THIS DRAWING AND/OR INFORMATION DELIVERED OR SUBMITTED ARE FULLY RESERVED CLA-VAL CO.®



CLA-VAL CO.

NEWPORT BEACH, CALIFORNIA

CATALOG NO.

129-01/629-01

DRAWING NO.

90490

REV.

B

TYPE OF VALVE AND MAIN FEATURES

MODULATING FLOAT VALVE

DESIGN

DRAW	CH	8-22-75
CHK'D	MF	9-5-75
AP'VD	JAW	9-9-75

OPERATING DATA—CONTINUED

III. CHECK LIST FOR PROPER OPERATION:

- () SYSTEM VALVES OPEN UPSTREAM AND DOWNSTREAM.
- () AIR REMOVED FROM THE MAIN VALVE COVER AND PILOT SYSTEM AT ALL HIGH POINTS.
- () CK2 COCKS (B) & (D3) OPEN (OPTIONAL FEATURE).
- () PERIODIC CLEANING OF STRAINER (Y) IS RECOMMENDED (OPTIONAL FEATURE).
- () CV FLOW CONTROLS (C) AND (S) OPEN AT LEAST 1/4 TURN (OPTIONAL FEATURE).
- () INDEPENDENT OPERATING PRESSURE CONNECTION PROPERLY CONNECTED. (OPTIONAL FEATURE).

CAD REVISION RECORD — DO NOT REVISE MANUALLY

DATE

BY

DESCRIPTION

LTR

SEE SHEET 1

THIS DRAWING IS THE PROPERTY OF CLA-VAL CO. AND SAME AND COPIES MADE THEREOF, IF ANY, SHALL BE RETURNED TO IT UPON DEMAND. DELIVERY AND DISCLOSURE HEREOF ARE SOLELY UPON CONDITION THAT THE SAME SHALL NOT BE USED, COPIED OR REPRODUCED, NOR SHALL THE SUBJECT HEREOF BE DISCLOSED IN ANY MANNER TO ANYONE FOR ANY PURPOSE, EXCEPT AS HEREIN AUTHORIZED, WITHOUT PRIOR WRITTEN APPROVAL OF CLA-VAL CO. THIS DRAWING IS SUBMITTED CONFIDENTIALLY AND MAY NOT BE USED IN THE MANUFACTURE OF ANY MATERIAL OR PRODUCT OTHER THAN SUCH MATERIALS AND PRODUCTS FURNISHED TO CLA-VAL CO. WHETHER OR NOT THE EQUIPMENT OR INFORMATION SHOWN HEREON IS PATENTED OR OTHERWISE PROTECTED, FULL TITLE AND COPYRIGHTS, IF ANY, IN AND TO THIS DRAWING AND/OR INFORMATION DELIVERED OR SUBMITTED ARE FULLY RESERVED CLA-VAL CO.

Float Valve



- Accurate and Repeatable Level Control
- Proportional Flow
- Reliable Hydraulic Operation
- Drip Tight Positive Shut-off
- Completely Automatic Operation

The Cla-Val Model 129-01/629-01 Float Valve maintains a relatively constant level in storage tanks and reservoirs by admitting flow into the tank in direct proportion to the flow out of the tank. It is a hydraulically operated, pilot controlled, diaphragm valve. The rotary disc type float operated pilot control is installed at the high liquid level in the reservoir and is connected via tubing or pipe to the main valve. As the liquid level changes, the float control proportionally opens or closes the main valve, keeping the liquid level nearly constant. If the check feature option is added and a pressure reversal occurs, the downstream pressure is admitted into the main valve cover chamber and the valve closes to prevent return flow.

Schematic Diagram

Item	Description
1	Hytrol (Main Valve)
2	X47A Ejector
3	Bell Reducer
4	CFM2 Float Control

Optional Features

Item	Description
A	X46A Flow Cleaner Strainer
B	CK2 (Isolation Valve)
C	CV Flow Control (Closing)
D	Check Valves With Isolation Valve
F	Independent Operating Pressure
S	CV Flow Control (Opening)
Y	X43 "Y" Strainer

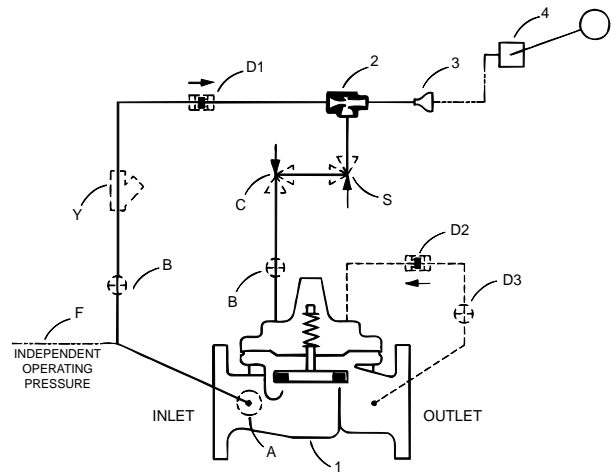

The "D" feature on a vertically installed 6" and larger valve must be horizontally installed.

Typical Applications

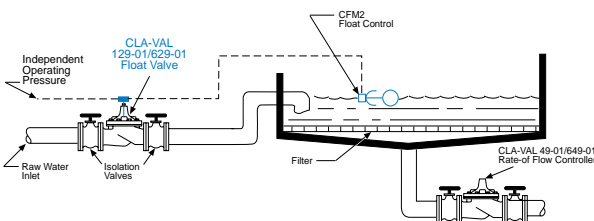

Piping and Tank Sizing

Install valve and control as shown in the diagram above. The float control should be located in a still liquid surface. If it is necessary to obtain this condition, a stilling well should be constructed. Mount the control on the connecting piping with the outlet port at the desired high water level.

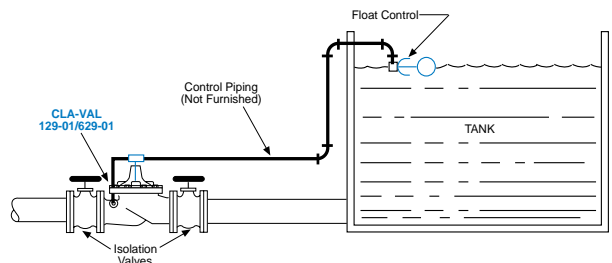

Filter Liquid Level Control

Maintains constant level in rapid sand filter. Usually requires the use of an independent operating pressure as shown.

Note: We recommend protecting tubing and valve from freezing temperatures.

Model 129-01 (Uses Basic Valve Model 100-01)

Pressure Ratings (Recommended Maximum Pressure - psi)

Valve Body & Cover		Pressure Class			
		Flanged			Threaded
Grade	Material	ANSI Standards*	150 lb.	300 lb.	End**
ASTM A536	Ductile Iron	B16.42	250	400	400
ASTM A216-WCB	Cast Steel	B16.5	285	400	400
ASTM B62	Bronze	B16.24	225	400	400
ASTM A743	Stainless Steel	B16.5	285	400	400
356-T6	Aluminum	B16.1	275	—	—

Note: *ANSI standards are for flange dimensions only.
 Flanged valves are available faced but not drilled.
 ** End Details machined to ANSI B2.1 specifications.



2" Globe, Threaded



4" Globe, Flanged



4" Angle, Flanged

Materials

Component	Material Options				
Body & Cover	Ductile Iron	Cast Steel	Bronze	Stainless Steel	Aluminum
Available Sizes	1½" - 16"	1¼" - 16"	1¼" - 16"	1¼" - 16"	1¼" - 16"
Disc Retainer & Diaphragm Washer	Cast Iron	Cast Steel	Bronze	Stainless Steel	Aluminum
Trim: Disc Guide, Seat & Cover Bearing	Bronze is standard. Stainless Steel is optional.			Stainless Steel is standard.	
Disc	Buna-N® Rubber				
Diaphragm	Nylon Reinforced Buna-N® Rubber				
Stem, Nut & Spring	Stainless Steel				

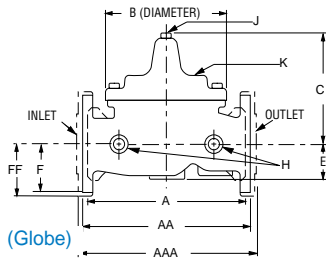

100-01 (Globe)

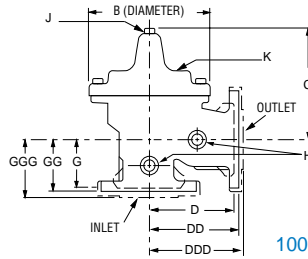

100-01 (Angle)

Model 129-01 Dimensions (In inches)

*1½" Size Only

VALVE SIZE (Inches)	1½ - 1½	2	2 ½	3	4	6	8	10	12	14	16
A Threaded	7.25	9.38	11.00	12.50	—	—	—	—	—	—	—
AA 150 ANSI	8.50*	9.38	11.00	12.00	15.00	20.00	25.38	29.75	34.00	39.00	41.38
AAA 300 ANSI	9.00*	10.00	11.62	13.25	15.62	21.00	26.38	31.12	35.50	40.50	43.50
B DIA.	5.62	6.62	8.00	9.12	11.50	15.75	20.00	23.62	28.00	32.75	35.50
C MAX..	5.50	6.50	7.56	8.19	10.62	13.38	16.00	17.12	20.88	24.19	25.00
D Threaded	3.25	4.75	5.50	6.25	—	—	—	—	—	—	—
DD 150 ANSI	4.00*	4.75	5.50	6.00	7.50	10.00	12.75	14.88	17.00	19.50	20.81
DDD 300 ANSI	4.25*	5.00	5.88	6.38	7.88	10.50	13.25	15.56	17.75	20.25	21.62
E	1.12	1.50	1.69	2.56	3.19	4.31	5.31	9.25	10.75	12.62	15.50
F 150 ANSI	2.50	3.00	3.50	3.75	4.50	5.50	6.75	8.00	9.50	10.50	11.75
FF 300 ANSI	3.06	3.25	3.75	4.13	5.00	6.25	7.50	8.75	10.25	11.50	12.75
G Threaded	1.88	3.25	4.00	4.50	—	—	—	—	—	—	—
GG 150 ANSI	4.00*	3.25	4.00	4.00	5.00	6.00	8.00	8.62	13.75	14.88	15.69
GGG 300 ANSI	4.25*	3.50	4.31	4.38	5.31	6.50	8.50	9.31	14.50	15.62	16.50
H NPT Body Tapping	¾	¾	½	½	¾	¾	1	1	1	1	1
J NPT Cover Center Plug	¼	½	½	½	¾	¾	1	1	1¼	1 ½	2
K NPT Cover Tapping	¾	¾	½	½	¾	¾	1	1	1	1	1
Valve Stem Internal Thread UNF	10-32	10-32	10-32	¼-28	¼-28	⅜-24	⅜-24	⅜-24	⅜-24	⅜-24	½-20
Stem Travel	0.4	0.6	0.7	0.8	1.1	1.7	2.3	2.8	3.4	4.0	4.5
Approx. Ship Wt. Lbs.	15	35	50	70	140	285	500	780	1165	1600	2265

Model 629-01 (Uses Basic Valve Model 100-20)

Pressure Ratings (Recommended Maximum Pressure - psi)

Valve Body & Cover		Pressure Class		
		Flanged		
Grade	Material	ANSI Standards*	150 lb.	300 lb.
ASTM A-1536	Ductile Iron	B16.42	250	400
ASTM A216-WCB	Cast Steel	B16.5	285	400
ASTM B62	Bronze	B16.24	225	400
ASTM A743	Stainless Steel	B16.5	285	400
356-T6	Aluminum	B16.1	275	—

Note: *ANSI standards are for flange dimensions only.
Flanged valves are available faced but not drilled.



3" Globe, Flanged

Materials

Component	Material Options				
	Ductile Iron	Cast Steel	Bronze	Stainless Steel	Aluminum
Body & Cover					
Available Sizes	3"-30"	3"-30"	3"-16"	3"-16"	3"-16"
Disc Retainer & Diaphragm Washer	Cast Iron	Cast Steel	Bronze	Stainless Steel	Aluminum
Trim: Disc Guide, Seat & Cover Bearing	Bronze is standard. Stainless Steel is optional.			Stainless Steel is standard.	
Disc	Buna-N® Rubber				
Diaphragm	Nylon Reinforced Buna-N® Rubber				
Stem, Nut & Spring	Stainless Steel				



6" Globe, Flanged

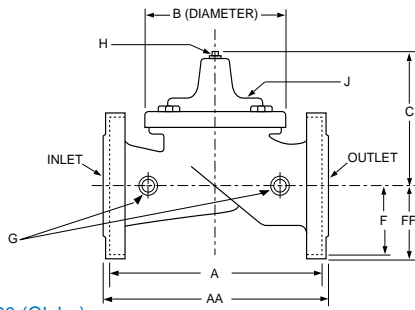

100-20 (Globe)

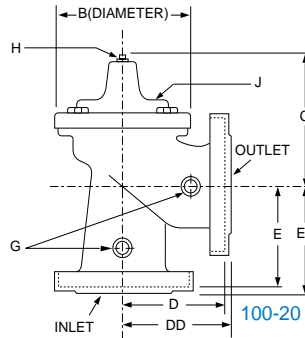

100-20 (Angle)













































6" Angle, Flanged

Model 629-01 Dimensions (In inches)

VALVE SIZE (Inches)	3	4	6	8	10	12	14	16	18	20	24	30
A 150 ANSI	10.25	13.88	17.75	21.38	26.00	30.00	34.25	35.00	42.12	48.00	48.00	63.25
AA 300 ANSI	11.00	14.50	18.62	22.38	27.38	31.50	—	36.62	43.63	49.62	49.75	—
B DIA.	6.62	9.12	11.50	15.75	20.00	23.62	28.00	28.00	35.44	35.44	35.44	53.19
C MAX.	7.00	8.62	11.62	15.00	17.88	21.00	20.88	25.75	25.00	31.00	31.00	43.94
D 150 ANSI	—	6.94	8.88	10.69	—	—	—	—	—	—	—	—
DD 300 ANSI	—	7.25	9.38	11.19	—	—	—	—	—	—	—	—
E 150 ANSI	—	5.50	6.75	7.25	—	—	—	—	—	—	—	—
EE 300 ANSI	—	5.81	7.25	7.75	—	—	—	—	—	—	—	—
F 150 ANSI	3.75	4.50	5.50	6.75	8.00	9.50	11.00	11.75	15.88	14.56	17.00	19.88
FF 300 ANSI	4.12	5.00	6.25	7.50	8.75	10.25	—	12.75	15.88	16.06	19.00	—
G NPT Body Tapping	3/8	1/2	3/4	3/4	1	1	1	1	1	1	1	1
H NPT Cover Center Plug	1/2	1/2	3/4	3/4	1	1	1 1/4	1 1/4	2	2	2	2
J NPT Cover Tapping	3/8	1/2	3/4	3/4	1	1	1	1	1	1	1	1
Valve Stem Internal Thread UNF	10-32	1/4-28	1/4-28	3/8-24	3/8-24	3/8-24	3/8-24	3/8-24	1/2-20	1/2-20	1/2-20	3/4-16
Stem Travel	0.6	0.8	1.1	1.7	2.3	2.8	3.4	3.4	4.5	4.5	4.5	6.5
Approx Ship Wt. Lbs.	45	85	195	330	625	900	1250	1380	2733	2551	2733	6500

Valve Selection

		These Symbols  and  Indicate Available Sizes																	
		Inches	1 1/4	1 1/2	2	2 1/2	3	4	6	8	10	12	14	16	18	20	24	30	
		mm	32	40	50	65	80	100	150	200	250	300	350	400	450	500	600	750	
		End Detail	Threaded	Threaded & Flanged				Flanged											
Model 129-01	Basic Valve 100-01	Globe																	
		Angle																	
	Suggested Flow (GPM)	Normal Continuous	93	125	210	300	460	800	1800	3100	4900	7000	8400	11000					
		Suggested Flow (Liters/sec)	6	8	13	19	29	50	113	195	309	441	529	693					
Model 629-01	Basic Valve 100-20	Globe																	
		Angle																	
	Suggested Flow (GPM)	Normal Continuous						260	580	1025	2300	4100	6400	9230	9230	16500	16500	16500	28000
		Suggested Flow (Liters/sec)						16	37	65	145	258	403	581	581	1040	1040	1040	1764

* 629-01 is the reduced internal port size version of the 129-01.

For 100-01 basic valves suggested flow calculations were based on flow through Schedule 40 Pipe. Normal continuous flow is approx. 20 ft/sec (6.1 meters/sec) .

For 100-20 basic valves suggested flow calculations were based on flow through the valve seat. Approx. 26 ft/sec (7.9 meters/sec) is used for normal continuous flow.

Normal continuous flow through the valve seat for the 30" 100-20 is approx. 20 ft/sec (6.1 meters/sec).

Important Notice: Do Not Oversize

**Flanged End Detail Only

Pilot System Dimensions (In Inches)

We recommend providing adequate space around valve for maintenance work

VALVE SIZE	1 1/4" & 1 1/2"	2"	2 1/2"	3"	4"	6"	8"	10"	12"	14"	16"	18"	20"	24"	30"
X	Max.	5.50	5.75	7.25	8.00	9.50	12.25	14.50	17.00	26.00	29.00	39.00	42.00	50.00	50.00
Y	Max.	4.00	4.00	4.50	5.00	6.00	8.00	10.25	12.00	14.25	16.75	18.00	18.00	30.00	30.00
Z	Max.	4.00	4.00	4.50	5.00	6.00	8.00	10.25	12.00	14.25	16.75	18.00	18.00	30.00	30.00

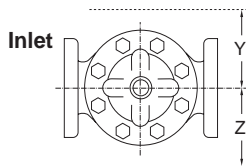

GLOBE

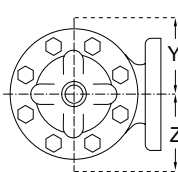
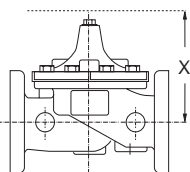

ANGLE

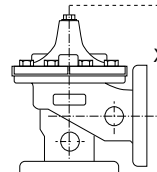

Inlet

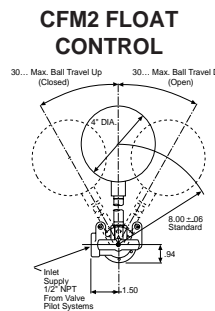

CFM2 FLOAT CONTROL

Pilot System Specifications

Pressure Ratings

Maximum: 300 psi

Temperature Range

Water: to 180°F

Materials

Pilot Control System:
Cast Bronze ASTM B-62 with
303 Stainless Steel Trim, Bronze
fittings and copper tubing.

Optional Materials

Aluminum, Bronze and Stainless Steel
available at extra cost.

Control Piping (customer supplied)

Use either copper tubing or brass pipe
between CFM2 Float Control and the main
valve pilot system.

1/2" dia. for distances less than 25 feet;

3/4" dia. for greater distances.

When Ordering, Please Specify

1. Catalog No. 129-01 or No. 629-01
2. Valve Size
3. Pattern - Globe or Angle
4. Pressure Class
5. Threaded or Flanged
6. Materials Desired
7. Desired Options
8. When Vertically Installed



CLA-VAL

PO Box 1325 Newport Beach CA 92659-0325
Phone: 949-722-4800 • Fax: 949-548-5441

CLA-VAL CANADA

4687 Christie Drive
Beamsville, Ontario
Canada LOR 1B4
Phone: 905-563-4963
Fax: 905-563-4040

CLA-VAL EUROPE

Chemin des Mésanges 1
CH-1032 Romanel/
Lausanne, Switzerland
Phone: 41-21-643-15-55
Fax: 41-21-643-15-50

COPYRIGHT CLA-VAL 2004 Printed in USA
Specifications subject to change without notice.

www.cla-val.com

Represented By:



— MODEL — **100-01**
Hytrol Valve

Description

The Cla-Val Model 100-01 Hytrol Valve is a main valve for Cla-Val Automatic Control Valves. It is a hydraulically operated, diaphragm-actuated, globe or angle pattern valve.

This valve consists of three major components; body, diaphragm assembly, and cover. The diaphragm assembly is the only moving part. The diaphragm assembly uses a diaphragm of nylon fabric bonded with synthetic rubber. A synthetic rubber disc, contained on three and one half sides by a disc retainer and disc guide, forms a seal with the valve seat when pressure is applied above the diaphragm. The diaphragm assembly forms a sealed chamber in the upper portion of the valve, separating operating pressure from line pressure.



Installation

1. Before valve is installed, pipe lines should be flushed of all chips, scale and foreign matter.
2. It is recommended that either gate or block valves be installed on both ends of the 100-01 Hytrol Valve to facilitate isolating the valve for preventive maintenance and repairs.
3. Place the valve in the line with flow through the valve in the direction indicated on the inlet nameplate. (See "Flow Direction" Section)
4. Allow sufficient room around valve to make adjustments and for disassembly.
5. Cla-Val 100-01 Hytrol Valves operate with maximum efficiency when mounted in horizontal piping with the cover UP, however,

other positions are acceptable. Due to size and weight of the cover and internal components of 8 inch and larger valves, installation with the cover UP is advisable. This makes internal parts readily accessible for periodic inspection.

6. If a pilot control system is installed on the 100-01 Hytrol Valve, use care to prevent damage. If it is necessary to remove fittings or components, be sure they are kept clean and replaced exactly as they were.

7. After the valve is installed and the system is first pressurized, vent air from the cover chamber and pilot system tubing by loosening fittings at all high points.

Principles of Operation

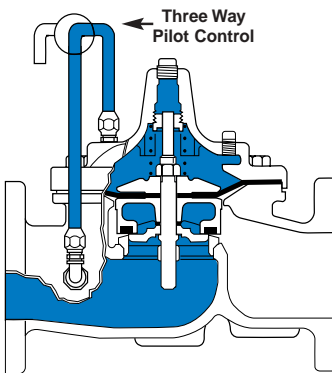

Tight Closing Operation

When pressure from the valve inlet (or an equivalent independent operating pressure) is applied to the diaphragm chamber the valve closes drip-tight.

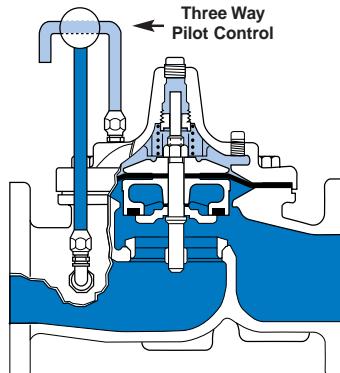

Full Open Operation

When pressure in diaphragm chamber is relieved to a zone of lower pressure (usually atmosphere) the line pressure (5 psi Min.) at the valve inlet opens the valve.

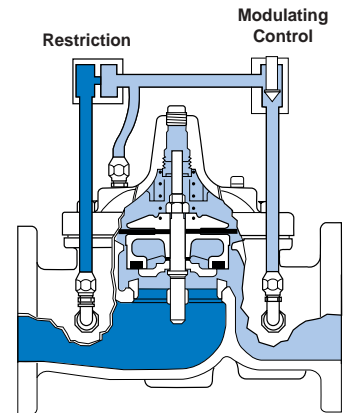

Modulating Action

Valve modulates when diaphragm pressure is held at an intermediate point between inlet and discharge pressure. With the use of a Cla-Val. "modulating control," which reacts to line pressure changes, the pressure above the diaphragm is varied, allowing the valve to throttle and compensate for the change.

Flow Direction

The flow through the 100-01 Hytrol Valve can be in one of two directions. When flow is “up-and-over the seat,” it is in “normal” flow and the valve will fail in the open position. When flow is “over-the seat-and down,” it is in “reverse” flow and the valve will fail in the closed position. There are no permanent flow arrow markings.

The valve must be installed according to nameplate data.

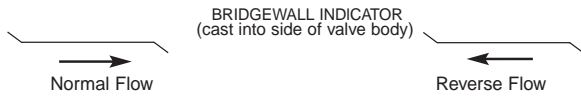

Recommended Tools

1. Three pressure gauges with ranges suitable to the installation to be put at Hytrol inlet, outlet and cover connections.
2. Cla-Val Model X101 Valve Position Indicator. This provides visual indication of valve position without disassembly of valve.
3. Other items are: suitable hand tools such as screwdrivers, wrenches, etc. soft jawed (brass or aluminum) vise, 400 grit wet or dry sandpaper and water for cleaning.

Troubleshooting

The following troubleshooting information deals strictly with the Model 100-01 Hytrol Valve. This assumes that all other components of the pilot control system have been checked out and are in proper working condition. (See appropriate sections in Technical Manual for complete valve).

All trouble shooting is possible without removing the valve from the line or removing the cover. It is highly recommended to permanently install a Model X101 Valve Position Indicator and three gauges in unused Hytrol inlet, outlet and cover connections.

SYMPTOM	PROBABLE CAUSE	REMEDY
Fails to Close	Closed isolation valves in control system, or in main line.	Open Isolation valves.
	Lack of cover chamber pressure.	Check upstream pressure, pilot system, strainer, tubing, valves, or needle valves for obstruction.
	Diaphragm damaged. (See Diaphragm Check.)	Replace diaphragm.
	Diaphragm assembly inoperative. Corrosion or excessive scale build up on valve stem. (See Freedom of Movement Check)	Clean and polish stem. Inspect and replace any damaged or badly eroded part.
	Mechanical obstruction. Object lodged in valve. (See Freedom of Movement Check)	Remove obstruction.
	Worn disc. (See Tight Sealing Check)	Replace disc.
	Badly scored seat. (See Tight Sealing Check)	Replace seat.
Fails to Open	Closed upstream and/or downstream isolation valves in main line.	Open isolation valves.
	Insufficient line pressure.	Check upstream pressure. (Minimum 5 psi flowing line pressure differential.)
	Diaphragm assembly inoperative. Corrosion or excessive buildup on valve stem. (See Freedom of Movement Check)	Clean and polish stem. Inspect and replace any damaged or badly eroded part.
	Diaphragm damaged. (For valves in "reverse flow" only)	Replace diaphragm.

After checking out probable causes and remedies, the following three checks can be used to diagnose the nature of the problem before maintenance is started. They must be done in the order shown.

Three Checks

The 100-01 Hytrol Valve has only one moving part (the diaphragm and disc assembly). So, there are only three major types of problems to be considered.

First: Valve is stuck - that is, the diaphragm assembly is not free to move through a full stroke either from open to close or vice versa.

Second: Valve is free to move and can't close because of a worn out diaphragm.

Third: Valve leaks even though it is free to move and the diaphragm isn't leaking.

CAUTION:

*Care should be taken when doing the troubleshooting checks on the 100-01 Hytrol Valve. These checks do require the valve to open fully. This will either allow a high flow rate through the valve, or the downstream pressure will quickly increase to the inlet pressure. In some cases, this can be very harmful. Where this is the case, and there are no block valves in the system to protect the downstream piping, it should be realized that **the valve cannot be serviced under pressure**. Steps should be taken to remedy this situation before proceeding any further.*

Diaphragm Check (#1)

1. Shut off pressure to the Hytrol Valve by slowly closing upstream and downstream isolation valves. **SEE CAUTION.**
2. Disconnect or close all pilot control lines to the valve cover and leave only one fitting in highest point of cover open to atmosphere.
3. With the cover vented to atmosphere, slowly open upstream isolation valve to allow some pressure into the Hytrol Valve body. Observe the open cover tapping for signs of continuous flow. It is not necessary to fully open isolating valve. Volume in cover chamber capacity chart will be displaced as valve moves to open position. Allow sufficient time for diaphragm assembly to shift positions. If there is no continuous flow, you can be quite certain the diaphragm is sound and the diaphragm assembly is tight. If the fluid appears to flow continuously this is a good reason to believe the diaphragm is either damaged or it is loose on the stem. In either case, this is sufficient cause to remove the valve cover and investigate the leakage. (See "Maintenance" Section for procedure.)

COVER CHAMBER CAPACITY (Liquid Volume displaced when valve opens)

Valve size (inches)	Displacement	
	Gallons	Liters
1 1/4	.020	.07
1 1/2	.020	.07
2	.032	.12
2 1/2	.043	.16
3	.080	.30
4	.169	.64
6	.531	2.0
8	1.26	4.8
10	2.51	9.5
12	4.00	15.1
14	6.50	24.6
16	9.57	36.2
24	29.00	109.8
36	42.00	159.0

Freedom of Movement Check (#2)

4. Determining the Hytrol Valve's freedom of movement can be done by one of two methods.
5. For most valves it can be done after completing Diaphragm Check (Steps 1, 2, and 3). **SEE CAUTION.** At the end of step 3 the valve should be fully open.
6. If the valve has a Cla-Val X101 Position Indicator, observe the indicator to see that the valve opens wide. Mark the point of maximum opening.
7. Re-connect enough of the control system to permit the application of inlet pressure to the cover. Open pilot system cock so pressure flows from the inlet into the cover.
8. While pressure is building up in the cover, the valve should close smoothly. There is a hesitation in every Hytrol Valve closure, which can be mistaken for a mechanical bind. The stem will appear to stop moving very briefly before going to the closed position. This slight pause is caused by the diaphragm flexing at a particular point in the valve's travel and is not caused by a mechanical bind.
9. When closed, a mark should be made on the X101 Valve position indicator corresponding to the "closed" position. The distance between the two marks should be approximately the stem travel shown in chart.

STEM TRAVEL

(Fully Open to Fully Closed)

Valve Size (inches)		Travel (inches)	
Inches	MM	Inches	MM
1 1/4	32	0.4	10
1 1/2	40	0.4	10
2	50	0.6	15
2 1/2	65	0.7	18
3	80	0.8	20
4	100	1.1	28
6	150	1.7	43
8	200	2.3	58
10	250	2.8	71
12	300	3.4	86
14	350	4.0	100
16	400	4.5	114
24	600	6.5	165
36	900	8.5	216

10. If the stroke is different than that shown in stem travel chart this is a good reason to believe something is mechanically restricting the stroke of the valve at one end of its travel. If the flow does not stop through the valve when in the indicated "closed" position, the obstruction probably is between the disc and the seat. If the flow does stop, then the obstruction is more likely in the cover. In either case, the cover must be removed, and the obstruction located and removed. The stem should also be checked for scale build-up. (See "Maintenance, section for procedure.)

11. For valves 6" and smaller, the Hytrol Valve's freedom of movement check can also be done after all pressure is removed from the valve. **SEE CAUTION.** After closing inlet and outlet isolation valves and bleeding pressure from the valve, check that the cover chamber and the body are temporarily vented to atmosphere. Insert fabricated tool into threaded hole in top of valve stem, and lift the diaphragm assembly manually. Note any roughness. The diaphragm assembly should move smoothly throughout entire valve stroke. The tool is fabricated from rod that is threaded on one end to fit valve stem and has a "T" bar handle of some kind on the other end for easy gripping. (See chart in Step 4 of "Disassembly" Section.)

12. Place marks on this diaphragm assembly lifting tool when the valve is closed and when manually positioned open. The distance between the two marks should be approximately the stem travel shown in stem travel chart. If the stroke is different than that shown, there is a good reason to believe something is mechanically restricting the stroke of the valve. The cover must be removed, and the obstruction located and removed. The stem should also be checked for scale build-up. (See "Maintenance" Section for procedure.)

Tight Sealing Check (#3)

13. Test for seat leakage after completing checks #1 & #2 (Steps 1 to 12). **SEE CAUTION.** Close the isolation valve downstream of the Hytrol Valve. Apply inlet pressure to the cover of the valve, wait until it closes. Install a pressure gauge between the two closed valves using one of the two ports in the outlet side of the Hytrol. Watch the pressure gauge. If the pressure begins to climb, then either the downstream isolation valve is permitting pressure to creep back, or the Hytrol is allowing pressure to go through it. Usually the pressure at the Hytrol inlet will be higher than on the isolation valve discharge, so if the pressure goes up to the inlet pressure, you can be sure the Hytrol is leaking. Install another gauge downstream of isolating valve. If the pressure between the valves only goes up to the pressure on the isolation valve discharge, the Hytrol Valve is holding tight, and it was just the isolation valve leaking.

Maintenance

Preventative Maintenance

The Cla-Val Co. Model 100-01 Hytrol Valve requires no lubrication or packing and a minimum of maintenance. However, a periodic inspection schedule should be established to determine how the operating conditions of the system are affecting the valve. The effect of these actions must be determined by inspection.

Disassembly

Inspection or maintenance can be accomplished without removing the valve from the line. Repair kits with new diaphragm and disc are recommended to be on hand before work begins.

WARNING: Maintenance personnel can be injured and equipment damaged if disassembly is attempted with pressure in the valve. **SEE CAUTION.**

1. Close upstream and downstream isolation valves **and independent operating pressure when used** to shut off all pressure to the valve.
2. Loosen tube fittings in the pilot system to remove pressure from valve body and cover chamber. After pressure has been released from the valve, use care to remove the controls and tubing. Note and sketch position of tubing and controls for re-assembly. The schematic in front of the Technical Manual can be used as a guide when reassembling pilot system.
3. Remove cover nuts and remove cover. If the valve has been in service for any length of time, chances are the cover will have to be loosened by driving upward along the edge of the cover with a **dull cold chisel**.

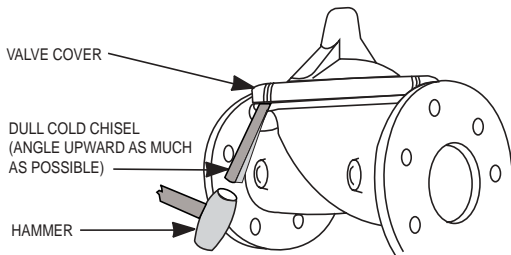

On 6" and smaller valves block and tackle or a power hoist can be used to lift valve cover by inserting proper size eye bolt in place of the center cover plug. on 8" and larger valves there are 4 holes (5/8" — 11 size) where jacking screws and/or eye bolts may be inserted for lifting purposes. **Pull cover straight up** to keep from damaging the integral seat bearing and stem.

COVER CENTER PLUG SIZE

Valve Size	Thread Size (NPT)
1 1/4"—1 1/2"	1/4"
2"—3"	1/2"
4"—6"	3/4"
8"—10"	1"
12"	1 1/4"
14"	1 1/2"
16"	2"
24"	2"
36"	2"

4. Remove the diaphragm and disc assembly from the valve body. With smaller valves this can be accomplished by hand by **pulling straight up on the stem so as not to damage the seat bearing**. On large valves, an eye bolt of proper size can be installed in the stem and the diaphragm assembly can be then lifted with a block and tackle or power hoist. Take care not to damage the stem or bearings. The valve won't work if these are damaged.

VALVE STEM THREAD SIZE

Valve Size	Thread Size (UNF Internal)
1 1/4"—2 1/2"	10—32
3"—4"	1/4—28
6"—14"	3/8—24
16"	1/2—20
24"	3/4-16
36"	3/4-16

5. The next item to remove is the stem nut. Examine the stem threads above the nut for signs of mineral deposits or corrosion. If the threads are not clean, use a wire brush to remove as much of the residue as possible. Attach a good fitting wrench to the nut and give it a sharp "rap" rather than a steady pull. Usually several blows are sufficient to loosen the nut for further removal. On the smaller valves, the entire diaphragm assembly can be held by the stem in a vise **equipped with soft brass jaws** before removing the stem nut.

The use of a pipe wrench or a vise without soft brass jaws scars the fine finish on the stem. No amount of careful dressing can restore the stem to its original condition. Damage to the finish of the stem can cause the stem to bind in the bearings and the valve will not open or close.

6. After the stem nut has been removed, the diaphragm assembly breaks down into its component parts. Removal of the disc from the disc retainer can be a problem if the valve has been in service for a long time. Using two screwdrivers inserted along the outside edge of the disc usually will accomplish its removal. Care should be taken to preserve the spacer washers in water, particularly if no new ones are available for re-assembly.

7. The only part left in the valve body is the seat which ordinarily does not require removal. Careful cleaning and polishing of inside and outside surfaces with 400 wet/dry sandpaper will usually restore the seat's sharp edge. If, however, it is badly worn and replacement is necessary, it can be easily removed.

Seats in valve sizes 1 1/4" through 6" are threaded into the valve body. They can be removed with accessory X109 Seat Removing Tool available from the factory. On 8" and larger valves, the seat is held in place by flat head machine screws. Use a tight-fitting, long shank screwdriver to prevent damage to seat screws. If upon removal of the screws the seat cannot be lifted out, it will be necessary to use a piece of angle or channel iron with a hole drilled in the center. Place it across the body so a long stud can be inserted through the center hole in the seat and the hole in the angle iron. By tightening the nut a uniform upward force is exerted on the seat for removal.

NOTE: Do not lift up on the end of the angle iron as this may force the integral bearing out of alignment, causing the stem to bind.

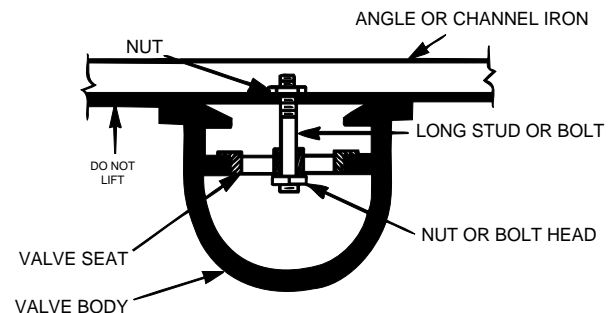

Lime Deposits

One of the easiest ways to remove lime deposits from the valve stem or other metal parts is to dip them in a 5-percent muriatic acid solution just long enough for the deposit to dissolve. This will remove most of the common types of deposits. **CAUTION: USE EXTREME CARE WHEN HANDLING ACID.** Rinse parts in water before handling. If the deposit is not removed by acid, then a fine grit (400) wet or dry sandpaper can be used with water.

Inspection of Parts

After the valve has been disassembled, each part should be examined carefully for signs of wear, corrosion, or any other abnormal condition. Usually, it is a good idea to replace the rubber parts (diaphragm and disc) unless they are free of signs of wear. These are available in a repair kit. Any other parts which appear doubtful should be replaced. **WHEN ORDERING PARTS, BE SURE TO GIVE COMPLETE NAMEPLATE DATA, ITEM NUMBER AND DESCRIPTION.**

NOTE: If a new disc isn't available, the existing disc can be turned over, exposing the unused surface for contact with the seat. The disc should be replaced as soon as practical.

Reassembly

1. Reassembly is the reverse of the disassembly procedure. If a new disc has been installed, it may require a different number of spacer washers to obtain the right amount of "grip" on the disc. When the diaphragm assembly has been tightened to a point where the diaphragm cannot be twisted, the disc should be compressed very slightly by the disc guide. Excessive compression should be avoided. Use just enough spacer washers to hold the disc firmly without noticeable compression.

2. MAKE SURE THE STEM NUT IS VERY TIGHT. Attach a good fitting wrench to the nut and give it a sharp "rap" rather than a steady pull. Usually several blows are sufficient to tighten the stem nut for final tightening. Failure to do so could allow the diaphragm to pull loose and tear when subjected to pressure.

3. Carefully install the diaphragm assembly by lowering the stem through the seat bearing. Take care not to damage the stem or bearing. Line up the diaphragm holes with the stud or bolt holes on the body. On larger valves with studs, it may be necessary to hold the diaphragm assembly up part way while putting the diaphragm over the studs.

4. Put spring in place and replace cover. Make sure diaphragm is lying smooth under the cover.

5. Tighten cover nuts firmly using a cross-over pattern until all nuts are tight.

6. Test Hytrol Valve before re-installing pilot valve system.

Test Procedure After Valve Assembly

There are a few simple tests which can be made in the field to make sure the Hytrol Valve has been assembled properly. Do these before installing pilot system and returning valve to service. These are similar to the three troubleshooting tests.

1. Check the diaphragm assembly for freedom of movement after all pressure is removed from the valve. **SEE CAUTION.** Insert fabricated tool into threaded hole in top of valve stem, and lift the diaphragm assembly manually. Note any roughness, sticking or grabbing. The diaphragm assembly should move smoothly throughout entire valve stroke. The tool is fabricated from rod that is threaded on one end to fit valve stem (See chart in Step 4 of "Disassembly" section.) and has a "T" Bar handle of some kind on the other end for easy gripping.

Place marks on this diaphragm assembly lifting tool when the valve is closed and when manually positioned open. The distance between the two marks should be approximately the stem travel shown in stem travel chart. (See "Freedom of Movement Check" section.) If the stroke is different than that shown, there is a good reason to believe something is mechanically restricting the stroke of the valve. The cover must be removed, the obstruction located and removed. (See "Maintenance" Section for procedure.)

Due to the weight of the diaphragm assembly this procedure is not possible on valves 8" and larger. On these valves, the same determination can be made by carefully introducing a low pressure (less than five psi) into the valve body with the cover vented. **SEE CAUTION.** Looking in cover center hole see the diaphragm assembly lift easily without hesitation, and then settle back easily when the pressure is removed.

2. To check the valve for drip-tight closure, a line should be connected from the inlet to the cover, and pressure applied at the inlet of the valve. If properly assembled, the valve should hold tight with as low as ten PSI at the inlet. See "Tight Sealing Check" section.)

3. With the line connected from the inlet to the cover, apply full working pressure to the inlet. Check all around the cover for any leaks. Re-tighten cover nuts if necessary to stop leaks past the diaphragm.

4. Remove pressure, then re-install the pilot system and tubing exactly as it was prior to removal. **Bleed air from all high points.**

5. Follow steps under "Start-Up and Adjustment" Section in Technical Manual for returning complete valve back to service.

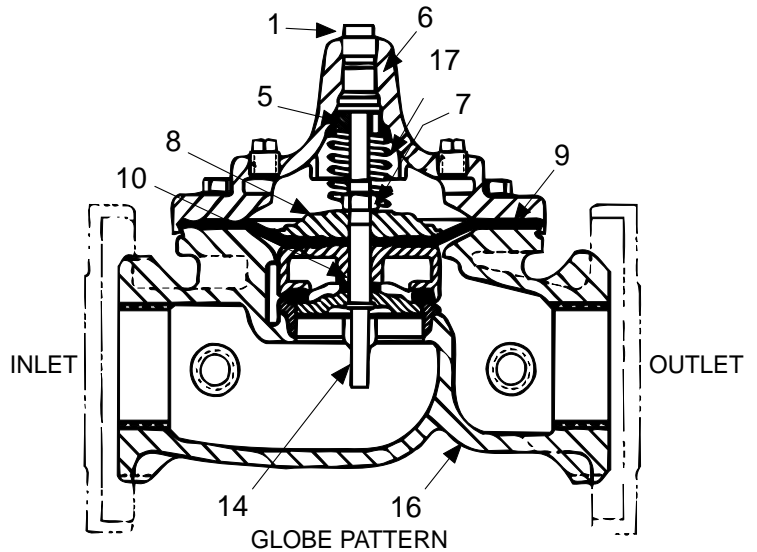
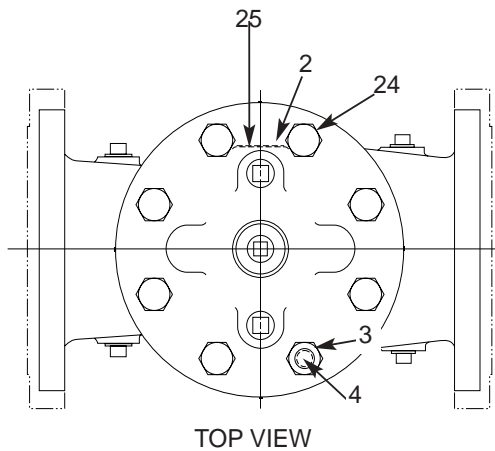

PARTS LIST

Item	Description
1.	Pipe Plug
2.	Drive Screws (for nameplate)
3.	Hex Nut (8" and larger)
4.	Stud (8" and larger)
5.	Cover Bearing
6.	Cover
7.	Stem Nut
8.	Diaphragm Washer
9.	Diaphragm
10.	Spacer Washers
11.	Disc Guide
12.	Disc Retainer
13.	Disc
14.	Stem
15.	Seat
16.	Body
17.	Spring
22.	Flat Head Screws (8" and larger)
23.	Seat O-Ring
24.	Hex head Bolt (1 1/4" thru 4")
25.	Nameplate
26.	Upper Spring Washer (Epoxy coated valves only)
27.	Lower Spring Washer (Epoxy coated valves only)
28.	Cover Bearing Housing (16" only)
29.	Cover O-Ring (16" only)
30.	Hex Bolt (16" only)
31.	Pipe Cap (16" only)

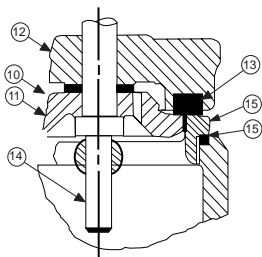
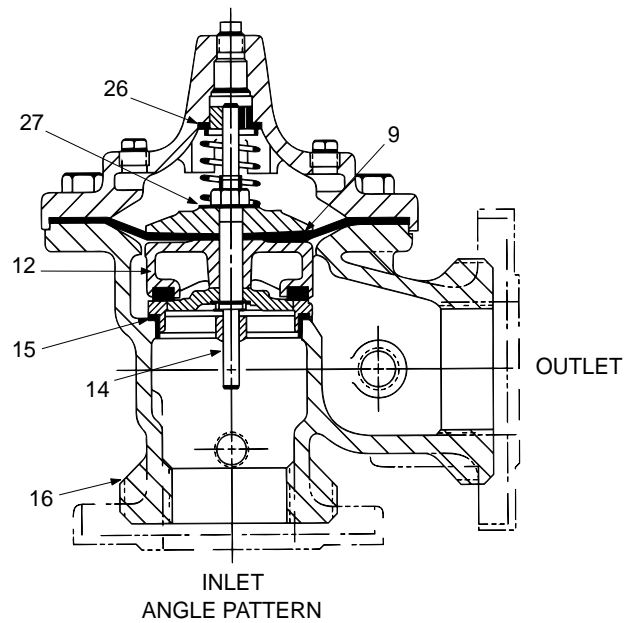

1 1/4" - 6" SEAT DETAIL

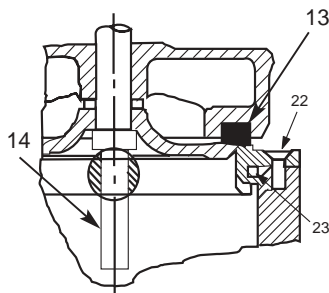

8" - 24" SEAT DETAIL

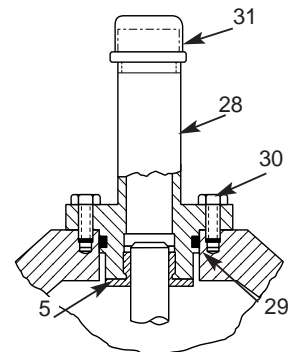

16" COVER DETAIL



— MODEL — **100-20**

600 Series Hytrol Valve

SERVICE AND MAINTENANCE OF 600 SERIES VALVES

The 600 series main valves have only one part -the body- that is different from standard 100 Series Cla-Val main valve parts. The remaining parts of the 600 series main valve are standard Cla-Val main valve parts. All service and maintenance information for the standard 100 Series main valves in this manual also apply to the 600 series main valves.

The most important thing to remember when ordering main valve repair kits and replacement parts, except for the body, all other parts are going to be for a smaller size main valve. Cla-Val identifies main valve parts with the flange size of the standard 100 Series main valve. Refer to the "Main Valve Sizes Comparison" chart. For example, if you are servicing a 6" 100-20 Hytrol and needed a repair kit, you would order a repair kit for a 4" 100-01 Hytrol. This kit is also suitable for a 6" 100-20 Hytrol. Complete Technical Manuals include a repair kit data sheet N-RK that shows this relationship.

When you order repair parts, it is a good idea to include valve nameplate data (size, catalog number, and part number) and description of the parts desired. Do this to be sure parts will fit the valve you are working on and not be too big for it. Pilot controls and repair kits maintenance information remain the same for 100 or 600 Series valves.

UNDERSTANDING THE 600 SERIES VALVES

In 1987, Cla-Val introduced the Model 100-20 Hytrol as the basic main valve for the 600 Series of automatic control valves. To identify all new valves using the 100-20 Hytrol, an existing catalog number is modified. Making a 600 Series catalog number is simply done by using a "6" in front of the two digit catalog numbers or replacing the "2" with a "6" in three digit catalog numbers. Current schematics reflect both catalog numbers together separated by a slash (i.e. - 90-01/690-01, 58-02/658-02, 210-01/610-01, etc). Since these two valves 'share' the same catalog number and schematic, they provide the same function in a system. The only difference between the two valves is the relative capacity of the two main valve series.

The 100-01 Hytrol is the basic main valve for Cla-Val automatic control valves. This valve is the current version of the Clayton Hytrol valve design originated in 1936. The 100-01 Hytrol is designed as a full flow area valve. This means that the inlet, seat and outlet openings are the same size. Thus, the pressure drop is kept to a minimum for this globe style design.

The 100-20 Hytrol valve has all of the basic features and advantages of the original 100-01 Hytrol. Only one part has been changed - the body. It is designed with different size inlet, seat and outlet openings. The 100-20 Hytrol has inlet and outlet flanges one valve size larger than the seat opening size. This results in what is sometimes called a "reduced port" main valve. For example, a 4" 100-20 valve has a 3" seat. Note: valve size is always determined by the flange size. The following chart compares the 100-01 and the 100-20 main valves.

Basic Main Valve Sizes Comparison

Globe Pattern Valves		
Flange Size (inch)	Seat Size	
	100-01 (100 Series)	100-20 (600 Series)
3	3	2
4	4	3
6	5	4
8	8	6
10	10	8
12	12	10
14	14	
16	16	12
20		16
24		16
Angle Pattern Valves		
Flange Size (inch)	Seat Size	
	100-01 (100 Series)	100-20 (600 Series)
4	4	3
6	6	4
8	8	6

The 100-20 Hytrol is available only in ductile iron, 150 and 300 pressure class, and Bronze trim standard. Available extra cost main valve options include stainless steel trim, epoxy coating, Dura-Kleen stem, Delrin sleeved stem, and high temperature rubber parts. All four basic main valves have a 600 Series version available with all of the same benefits and size relationships. The following chart shows the relationship of Cla-Val main valve catalog numbers.

Cla-Val Main Valves

Catalog Name	Catalog Number		
	Circa 1936	100-Series	600 Series
Hytrol	100 (Angle =2100)	100-01	100-20
Powertrol	100P & 100PA	100-02	100-21
Powercheck	100PC & 100PCA	100-03	100-22
Hycheck	181	100-04	100-23

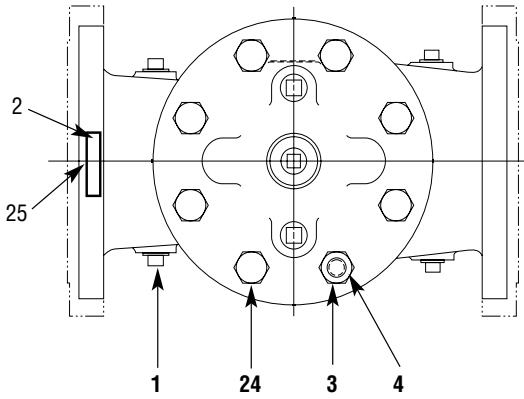

TOP VIEW

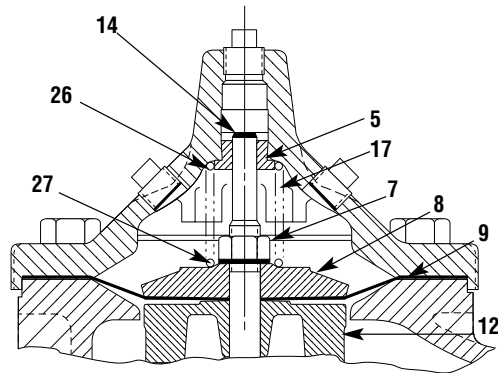
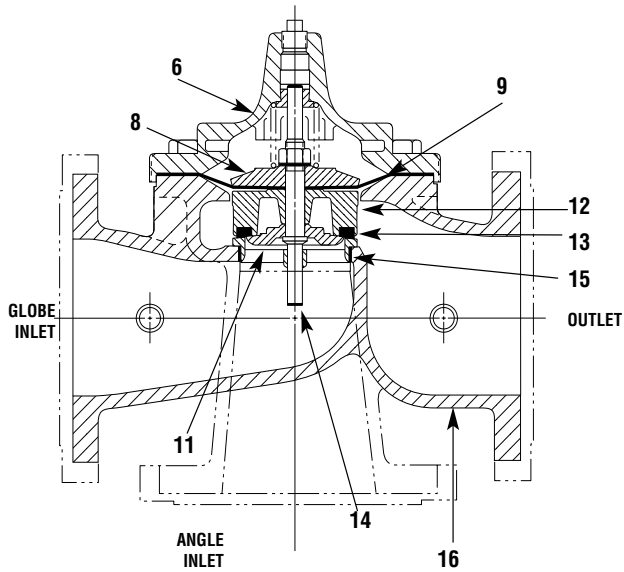

3" — 6" COVER DETAIL

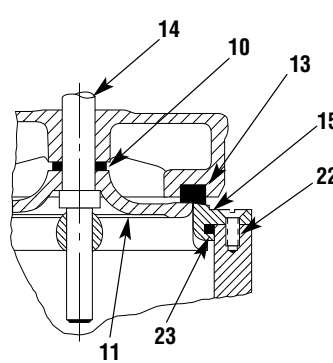

10" — 24" SEAT DETAIL

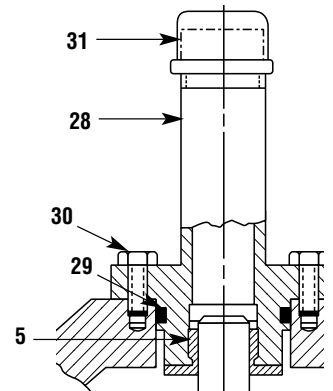

20" — 24" COVER DETAIL

PARTS LIST

NO.	DESCRIPTION
1	Pipe Plug
2	Drive Screws (for nameplate)
3	Hex Nut (8" and larger)
4	Stud (8" and larger)
5	Cover Bearing
6	Cover
7	Stem Nut
8	Diaphragm Washer
9	Diaphragm
10	Spacer Washers
11	Disc Guide
12	Disc Retainer
13	Disc
14	Stem
15	Seat
16	Body
17	Spring
22	Flat Head Screws (10" and larger)
23	Seat O-Ring
24	Hex Bolt (3 " Thru 6")
25	Nameplate (Mounted on inlet flange)
26	Upper Spring Washer (Epoxy coated valves only)
27	Lower Spring Washer (Epoxy coated valves only)
28	Cover Bearing Housing (20" & 24")
29	Cover Bearing Housing O-Ring (20" & 24")
30	Hex Bolt (20" & 24")
31	Pipe Cap (20" & 24")

WHEN ORDERING PARTS, BE SURE TO GIVE COMPLETE NAMEPLATE DATA, ITEM NUMBER AND DESCRIPTION.



X47A

3/8" Ejector

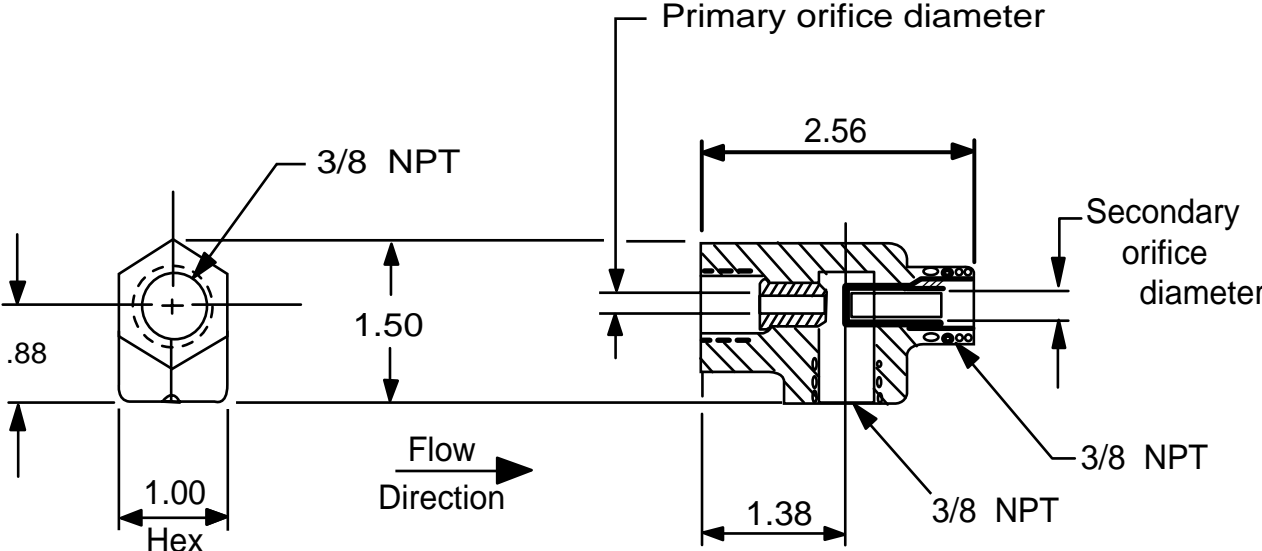

NOTE: Sold as complete assembly. No replacement parts available.

When ordering parts, please specify:

- Number Stamped on Side
- Description (X47A 3/8" Ejector)
- Orifice Dimensions
- Materials

BRONZE HOUSING - 303 S.S. INSERTS		
CLA-VAL X47A STK. NO.	ORIFICE DIAMETER	
	PRIMARY	SECONDARY
C4311B	1/16	3/32
C4312K	1/8	3/16
C4089D	3/16	9/32

303 S.S. HOUSING - 303 S.S. INSERTS		
CLA-VAL X47A STK. NO.	ORIFICE DIAMETER	
	PRIMARY	SECONDARY
32899H	1/16	3/32
C6168D	3/16	9/32
65274D	5/32	9/32



CFM2

Modulating Float Control

SIZE	STOCK NUMBER	DESCRIPTION
1/2"		W/COPPER FLOAT BALL, BRASS ARM AND BRASS ARM EXTENSION
1/2"		W/S.S. FLOAT BALL, ARM & ARM EXTENSION

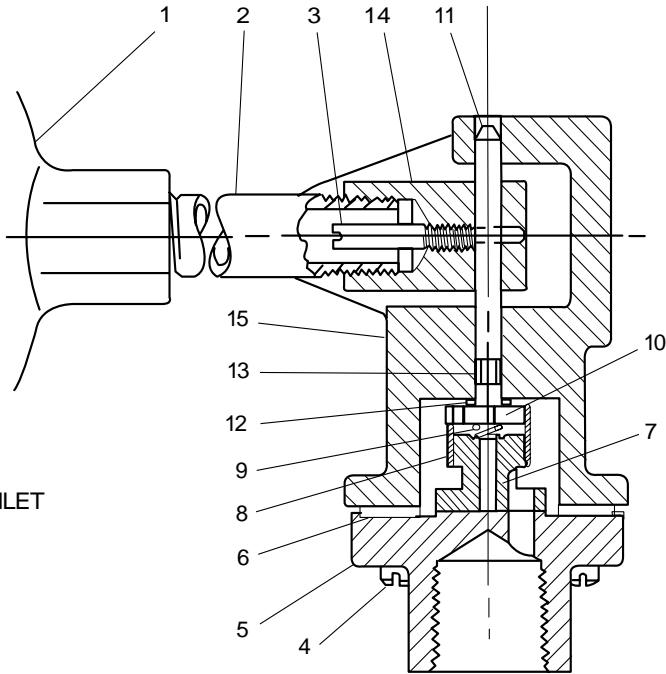
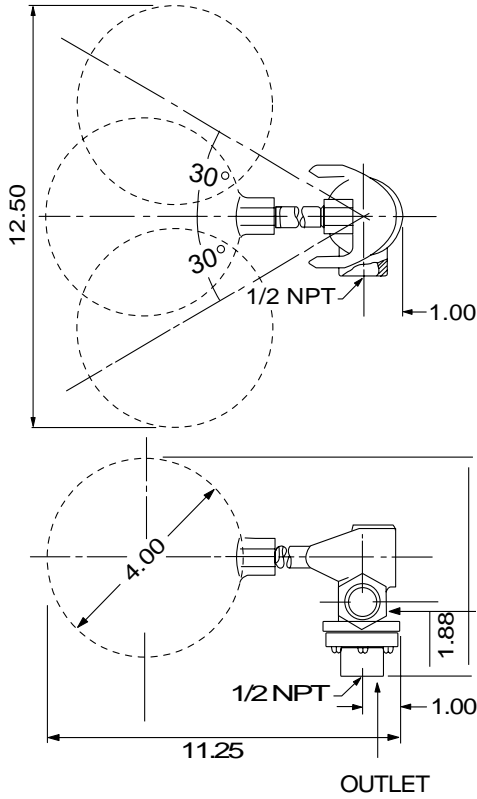

Item	Description	Material	Part No.
1	Float Ball	Copper for C-9582 S.S. for C-9580	C-1395 C-440
2	Arm Extension 1/4" Dia. X 5" Long	Brass for C-9582 S.S. for C-9580	67586-09 67586-25
3	Lock Pin	S.S.	TV-1327
4	Machine Screw, Fil. Hd. 6.32 x 5/8 (6 Req'd)	Brass for C-9582	67575-08 67575-24
5*	Distributor	S.S.	C-1392
6*	Gasket	Syn. Rub.	C-19

Item	Description	Material	Part No.
7 & 8*	†Disc Assembly (7-Disc / 8-Skirt)	Brass & Monel	C-7071
9*	Spring	S.S.	TV-1420
10 & 11	†Stem Assembly (10-Driver) (11-Stem)	Brass & S.S.	C-1304
12	Thrust Washer	Brass for C-9582 303 S.S. for C-9580	TV-5619 C-4430
13*	"O" Ring 3855-B	Syn. Rub.	00901
14	Float Arm	Brass for C-9582 S.S. for C-9580	C-1306 C-5085
15	Housing	Brass	83323-01

†Permanently Joined Assembly



— MODEL — **X46**

Flow Clean Strainer



X46A Straight

- Self Scrubbing Cleaning Action
- Straight Type or Angle Type

The Cla-Val Model X46 Strainer is designed to prevent passage of foreign particles larger than .015". It is especially effective against such contaminant as algae, mud, scale, wood pulp, moss, and root fibers. There is a model for every Cla-Val. valve.

X46B Angle

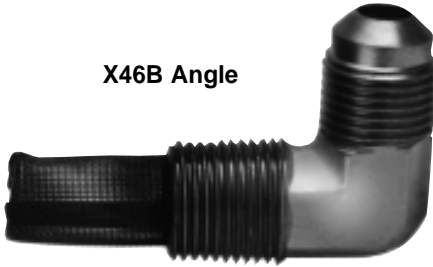

The X46 Flow Clean strainer operates on a velocity principle utilizing the circular "air foil" section to make it self cleaning. Impingement of particles is on the "leading edge" only. The low pressure area on the downstream side of the screen prevents foreign particles from clogging the screen. There is also a scouring action, due to eddy currents, which keeps most of the screen area clean.

Dimensions (In Inches)

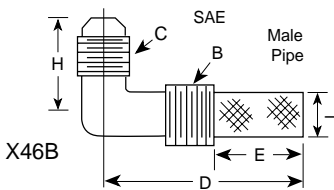

X46 Angle Type B (In Inches)						
B(NPT)	C(SAE)	D	E	H	I	
1/8	1/4	1-3/8	5/8	7/8	1/4	
1/4	1/4	1-3/4	3/4	1	3/8	
3/8	1/4	2	7/8	1	1/2	
3/8	3/8	1-7/8	7/8	1	1/2	
1/2	3/8	2-3/8	1	1-1/4	5/8	

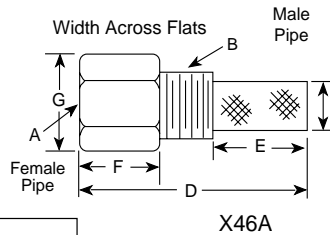

X46A Straight Type A (In Inches)						
A (NPT)	B (NPT)	D	E	F	G	I
1/8	1/8	1-3/4	3/4	1/2	1/2	1/4
1/4	1/4	2-1/4	1	3/4	3/4	3/8
3/8	3/8	2-1/2	1	7/8	7/8	1/2
3/8	1/2	2-1/2	1-1/4	1/2	7/8	3/4
1/2	1/2	3	1-1/4	1	1-1/8	3/4
3/8	3/4	3-3/8	2	1/2	1	7/8
3/4	3/4	4	2	1	1-1/2	7/8
3/8	1	4-1/4	2-3/4	1/2	1-3/8	7/8
1	1	4-1/2	2-3/4	1-1/4	1-3/4	7/8
1/2	1	4-1/4	2-3/4	1/2	1-3/8	7/8

When Ordering, Please Specify:

- Catalog Number X46
- Straight Type or Angle Type
- Size Inserted Into and Size Connection
- Materials

INSTALLATION

The strainer is designed for use in conjunction with a Cla-Val Main Valve, but can be installed in any piping system where there is a moving fluid stream to keep it clean. When it is used with the Cla-Val Valve, it is threaded into the upstream body port provided for it on the side of the valve. It projects through the side of the Main Valve into the flow stream. All liquid shunted to the pilot control system and to the cover chamber of the Main Valve passes through the X46 Flow Clean Strainer.

INSPECTION

Inspect internal and external threads for damage or evidence of cross-threading. Check inner and outer screens for clogging, embedded foreign particles, breaks, cracks, corrosion, fatigue, and other signs of damage.

DISASSEMBLY

Do not attempt to remove the screens from the strainer housing.

CLEANING

After inspection, cleaning of the X46 can begin. Water service usually will produce mineral or lime deposits on metal parts in contact with water. These deposits can be cleaned by dipping X46 in a 5-percent muriatic acid solution just long enough for deposit to dissolve. This will remove most of the common types of deposits. **Caution: use extreme care when handling acid.** If the deposit is not removed by acid, then a fine grit (400) wet or dry sandpaper can be used with water. Rinse parts in water before handling. An appropriate solvent can clean parts used in fueling service. Dry with compressed air or a clean, lint-free cloth. Protect from damage and dust until reassembled.

REPLACEMENT

If there is any sign of damage, or if there is the slightest doubt that the Model X46 Flow Clean Strainer may not afford completely satisfactory operation, replace it. Use Inspection steps as a guide. Neither inner screen, outer screen, nor housing is furnished as a replacement part. Replace Model X46 Flow Clean Strainer as a complete unit.

When ordering replacement Flow-Clean Strainers, it is important to determine pipe size of the tapped hole into which the strainer will be inserted (refer to column A or F), and the size of the external connection (refer to column B or G).

CLA-VAL CO. NEWPORT BEACH, CALIFORNIA	CATALOG NO.	DRAWING NO. 67783	REV AW
	TYPE OF VALVE AND MAIN FEATURES CK2 COCK/BALL VALVE		

04-07-03
 AK
 07-29-03
 AK
 REMOVED COLUMN "MONEL W/ LOCKING HANDLE"; RELOCATED PN 67783-56D;
 AV ADDED VENDOR INFO FOR PN 67783-56D ON SHEET 2 (ECO 19327)
 AW ADDED PN 67783-57B ON SHEET 1 (ECO 19484)

LTR	BY	DATE	AK	01-31-03
CAD REVISION RECORD - DO NOT REVISE MANUALLY				
DESCRIPTION				
A-AT SEE REVISION FILE				
AU ADDED PN 67783-56D (ECO 19284)				

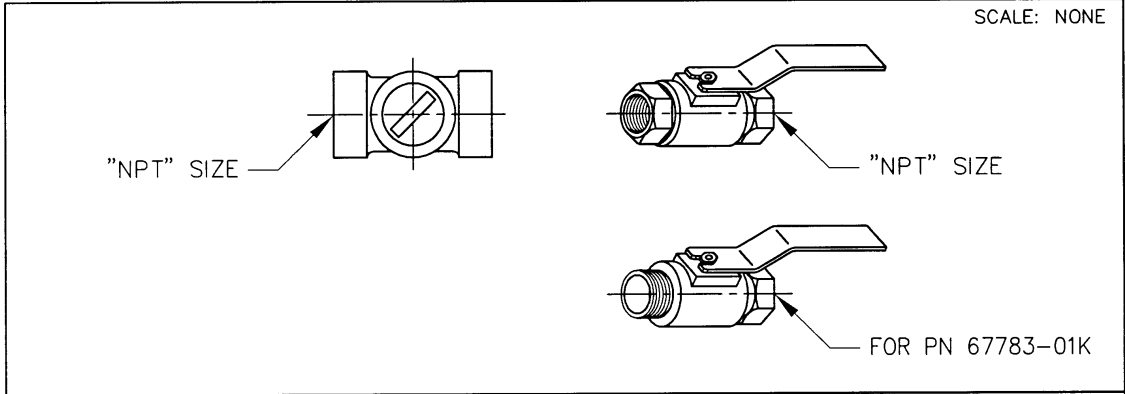

CLA-VAL PART NO. AND MATERIAL							
BRONZE WITH HANDLE	STEEL WITH HANDLE	IRON WITH HANDLE	316 SST WITH HANDLE	316 SST W/ LOCKING HANDLE	BRONZE WITH HANDLE	MONEL WITH HANDLE	SIZE "NPT"
67783-01K*	-09C	-17F	-25J SUPSD BY-26G		-41F SUPSD BY-01K		1/8"
-02H	-10A	-18D	-26G	-51E SUPSD BY-26G -52C	-42D SUPSD BY-02H	-55F	1/4"
-03F *	-11J	-19B	-27E	-46E SUPSD BY-27E -53A	-45G -57B **	-48A SUPSD BY-49J	3/8"
-04D	-12G	-20K	-28C	-54J	-43B SUPSD BY-04D	-49J	1/2"
-05A	-13E	-21H	-29A		-44K SUPSD BY-05A	-56D	3/4"
-06J	-14C	-22F	-30J				1"
-07G	-15K	-23D	-31G				1 1/4"
-08E	-16H	-24B	-32E				1 1/2"
-50G			-47C				2"

* SEE ENGINEERING APPROVED VENDORS TABLE (SHEET 2 OF 2).
 ** HAMMOND VALVE 8501 ONLY.

THIS DRAWING IS THE PROPERTY OF CLA-VAL CO. AND SAME AND COPIES MADE THEREOF, IF ANY, SHALL BE RETURNED TO IT UPON DEMAND. DELIVERY AND DISCLOSURE HEREOF ARE SOLELY UPON CONDITION THAT THE SAME SHALL NOT BE USED, COPIED OR REPRODUCED, NOR SHALL THE SUBJECT HEREOF BE DISCLOSED IN ANY MANNER TO ANYONE FOR ANY PURPOSE, EXCEPT AS HEREIN AUTHORIZED, WITHOUT PRIOR WRITTEN APPROVAL OF CLA-VAL CO. THIS DRAWING IS SUBMITTED CONFIDENTIALLY AND MAY NOT BE USED IN THE MANUFACTURE OF ANY MATERIAL OR PRODUCT OTHER THAN SUCH MATERIALS AND PRODUCTS FURNISHED TO CLA-VAL CO. WHETHER OR NOT THE EQUIPMENT OR INFORMATION SHOWN HEREON IS PATENTED OR OTHERWISE PROTECTED, FULL TITLE AND COPYRIGHTS, IF ANY, IN AND TO THIS DRAWING AND/OR INFORMATION DELIVERED OR SUBMITTED ARE FULLY RESERVED CLA-VAL CO.™

— MODEL — **CV****Flow Control****DESCRIPTION**

The Cla-Val Model CV Flow Control is a simply-designed, spring-loaded check valve. Rate of flow is full flow in one direction and restricted in other direction. Flow is adjustable in the restricted direction. It is intended for use in conjunction with a pilot control system on a Cla-Val Automatic Control Valve.

OPERATION

The CV Flow Control permits full flow from port A to B, and restricted flow in the reverse direction. Flow from port A to B lifts the disc from seat, permitting full flow. Flow in the reverse direction seats the disc, causing fluid to pass through the clearance between the stem and the disc. This clearance can be increased, thereby increasing the restricted flow, by screwing the stem out, or counter-clockwise. Turning the stem in, or clockwise reduces the clearance between the stem and the disc, thereby reducing the restricted flow.

INSTALLATION

Install the CV Flow Control as shown in the valve schematic. All connections must be tight to prevent leakage.

DISASSEMBLY

Follow the sequence of the item numbers assigned to the parts in the cross sectional illustration for recommended order of disassembly.

Use a scriber, or similar sharp-pointed tool to remove O-ring from the stem.

INSPECTION

Inspect all threads for damage or evidence of cross-threading. Check mating surface of seat and valve disc for excessive scoring or embedded foreign particles. Check spring for visible distortion, cracks and breaks. Inspect all parts for damage, corrosion and cleanliness.

CLEANING

After disassembly and inspection, cleaning of the parts can begin. Water service usually will produce mineral or lime deposits on metal parts in contact with water. These deposits can be cleaned by dipping the parts in a 5-percent muriatic acid solution just long enough for deposits to dissolve. This will remove most of the common types of deposits. **Caution: use extreme care when handling acid.** If the deposit is not removed by acid, then a fine grit (400) wet or dry sandpaper can be used with water. Rinse parts in water before handling. An appropriate solvent can clean parts used in fueling service. Dry with compressed air or a clean, lint-free cloth. Protect from damage and dust until reassembled.

REPAIR AND REPLACEMENT

Minor nicks and scratches may be polished out using a fine grade of emery or crocus cloth; replace parts if scratches cannot be removed.

Replace O-ring packing and gasket each time CV Flow Control is overhauled.

Replace all parts which are defective. Replace any parts which create the slightest doubt that they will not afford completely satisfactory operation. Use Inspection steps as a guide.

REASSEMBLY

Reassembly is the reverse of disassembly; no special tools are required.

TEST PROCEDURE

No testing of the flow Control is required prior to reassembly to the pilot control system on Cla-Val Main Valve.



CV

3/8" Flow Control

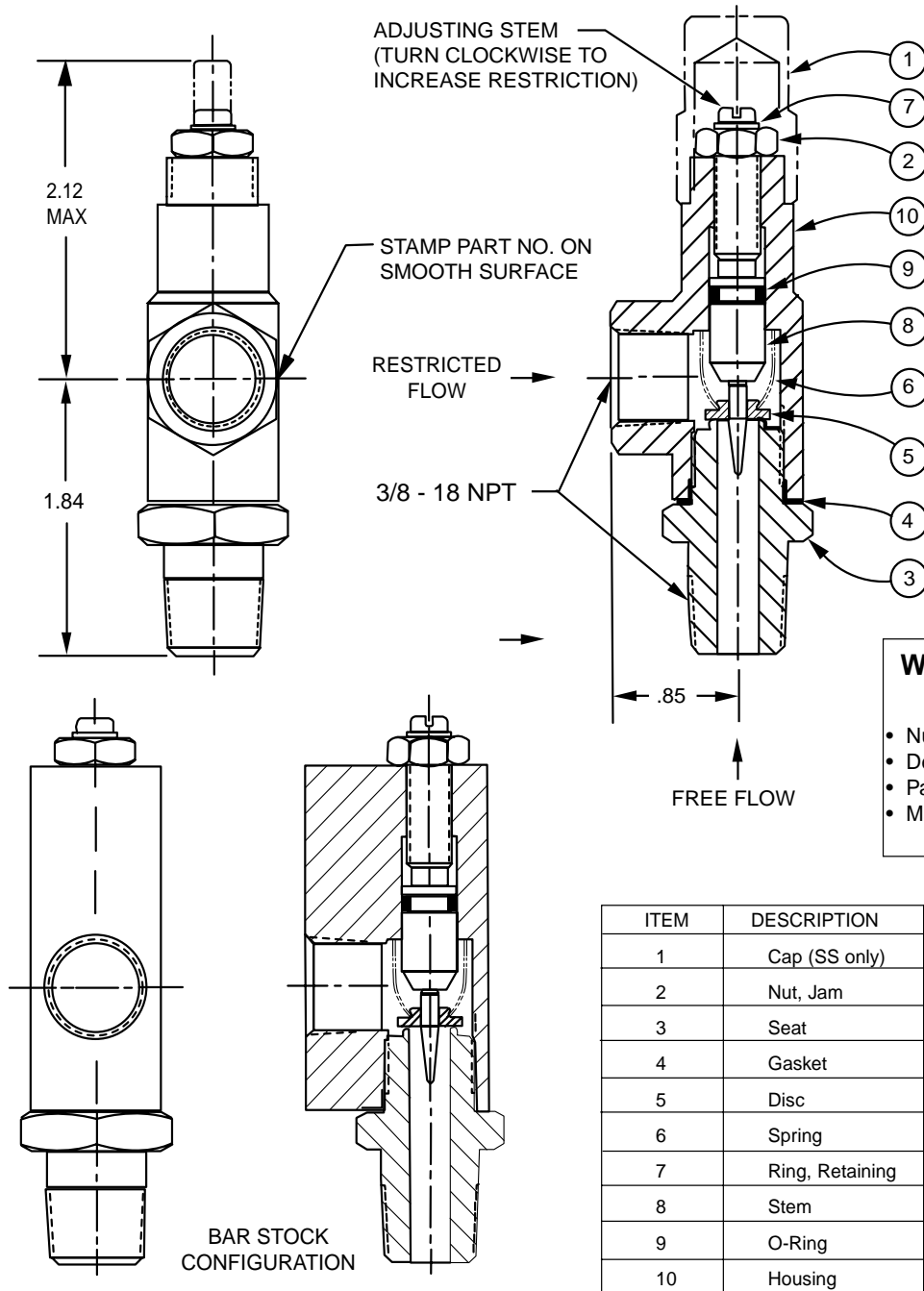



CDC-1 Check Valve

ITEM	DESCRIPTION
1	Retainer, Seal
2	O-Ring
3	Retainer, Valve
4	Seal, Valve Ring
5	Plate Valve

SIZE (NPT)	STOCK NUMBER	A (inch)	B HEX (Inch)
3/8	9834501A	2.06	1.06
1/2	9834502J	2.12	1.38

Material: Bronze

Available only in replacement assembly.

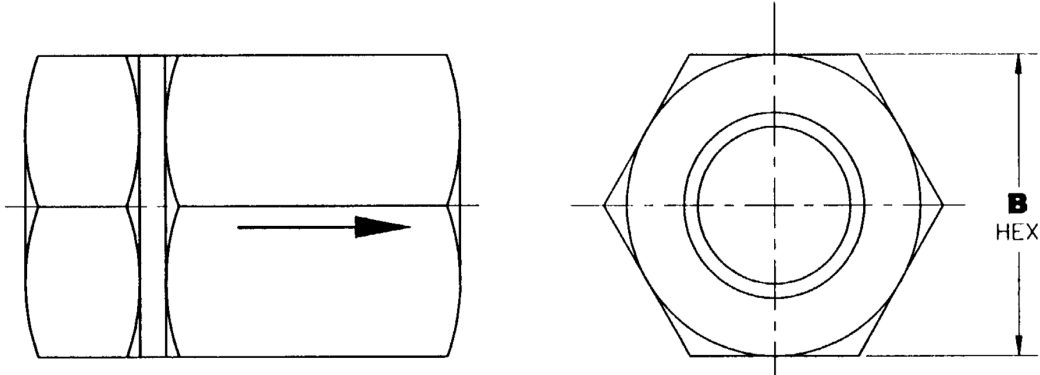
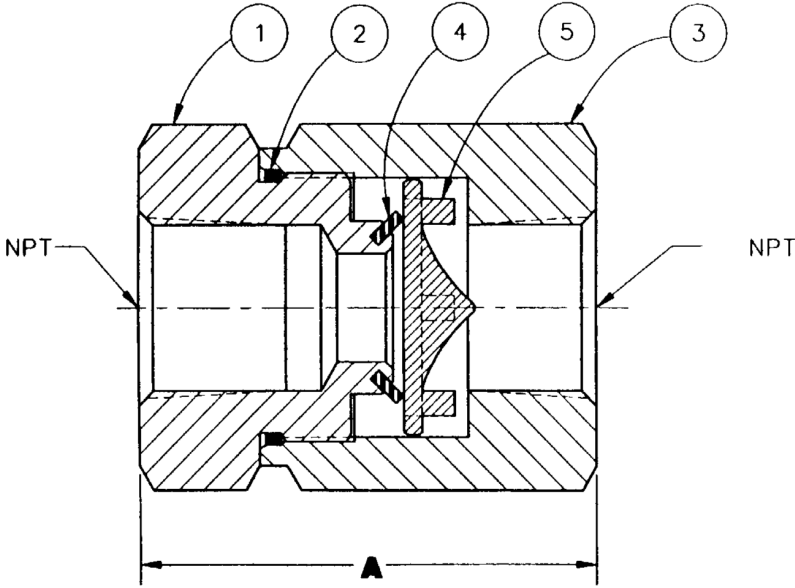



X43 Strainer

ITEM	DESCRIPTION	MATERIAL
1	Pipe Plug	Steel
2	Strainer Plug	Brass
3	Gasket	Copper
4*	Screen	Monel
5	Body	Brass

Standard 60 mesh pilot system strainer for fluid service.

SIZE	STOCK NUMBER
3/8 x 3/8	33450J

*Replacement screen stock number 68373A.
All other parts available only in replacement assembly.

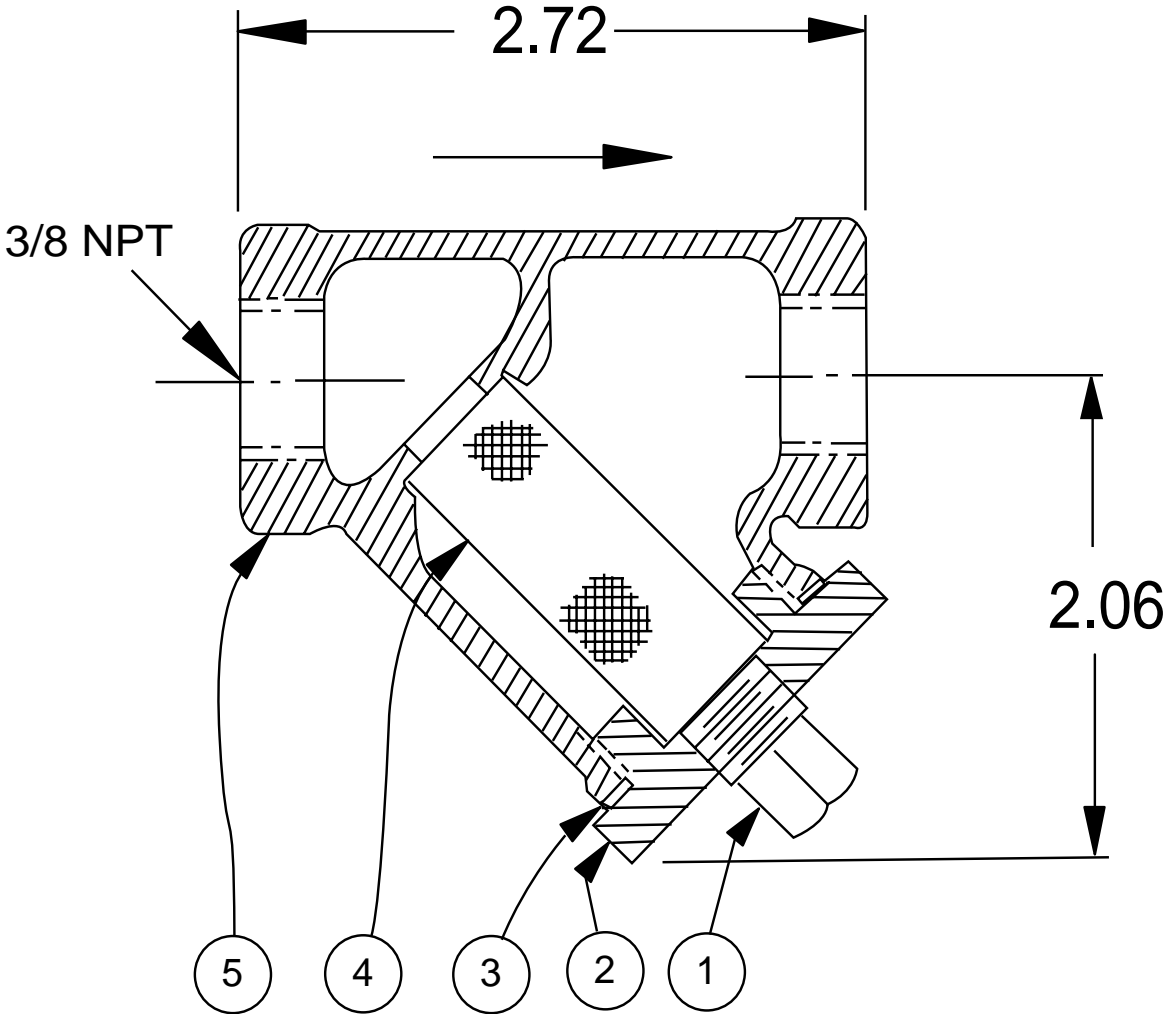

Proper Identification

For ordering repair kits, replacement parts, or for inquiries concerning valve operation it is important to properly identify Cla-Val products already in service. Include all nameplate data with your inquiry. Pertinent product data includes valve function, size, material, pressure rating, end details, type of pilot controls used and control adjustment ranges.

Identification Plates

For product identification, cast in body markings are supplemented by identification plates as illustrated on this page. The plates, depending on type and size of product, are mounted in the most practical position. **It is extremely important that these identification plates are not painted over, removed, or in any other way rendered illegible.**

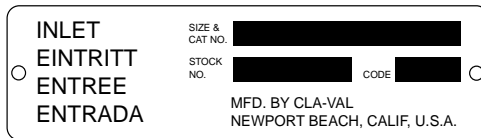

This brass plate appears on valves sized 2 1/2" and larger and is located on the top of the inlet flange.

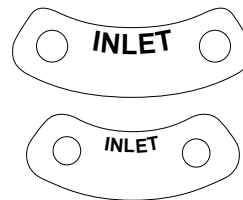

These two brass plates appear on 3/8", 1/2", and 3/4" size valves and are located on the valve cover.



This brass plate appears on altitude valves only and is found on top of the outlet flange.

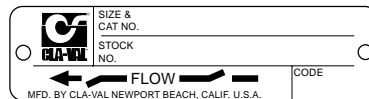

These two brass plates appear on 1" through 3" size screwed valves or 1" through 2" flanged valves. It is located on only one side of the valve body.

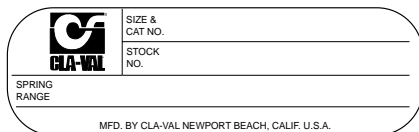

This tag is affixed to the cover of the pilot control valve. The adjustment range appears in the spring range section.

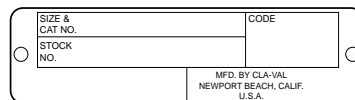

This brass plate is used to identify pilot control valves. The adjustment range is stamped into the plate.

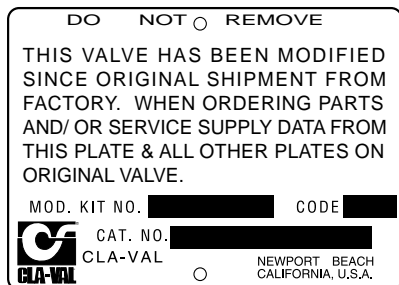

This aluminum plate is included in pilot system modification kits and is to be wired to the new pilot control system after installation.

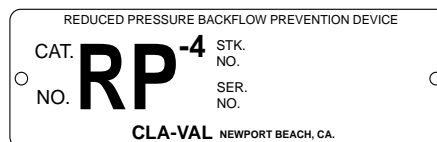

This brass plate is on our backflow prevention assemblies. It is located on the side of the number two check (2" through 10"). The serial number of the assembly is also stamped on the top of the inlet flange of the number one check.

HOW TO ORDER

There are many valves and controls manufactured by Cla-Val that are not listed due to the sheer volume. For information not listed, please contact your local Cla-Val office or our factory office located at:

P. O. Box 1325
Newport Beach, California 92659-0325
(949) 722-4800
FAX (949) 548-5441

SPECIFY WHEN ORDERING

- Model Number
- Globe or Angle Pattern
- Adjustment Range (As Applicable)
- Valve Size
- Screwed or Flanged
- Body and Trim Materials
- Optional Features
- Pressure Class

UNLESS OTHERWISE SPECIFIED

- Globe or angle pattern are the same price
- Ductile iron body and bronze trim are standard
- X46 Flow Clean Strainer or X43 "Y" Strainer are included
- CK2 Isolation Valves are included in price on 4" and larger valve sizes (6" and larger on 600 Series)

LIMITED WARRANTY

Automatic valves and controls as manufactured by Cla-Val are warranted for three years from date of shipment against manufacturing defects in material and workmanship which develop in the service for which they are designed, provided the products are installed and used in accordance with all applicable instructions and limitations issued by Cla-Val.

We will repair or replace defective material, free of charge, which is returned to our factory, transportation charges prepaid, provided that, after inspection, the material is found to have been defective at time of shipment. This warranty is expressly conditioned on the purchaser's giving Cla-Val immediate written notice upon discovery of the defect.

Components used by Cla-Val but manufactured by others, are warranted only to the extent of that manufacturer's guarantee.

This warranty shall not apply if the product has been altered or repaired by others, and Cla-Val shall make no allowance or credit for such repairs or alterations unless authorized in writing by Cla-Val.

DISCLAIMER OF WARRANTIES AND LIMITATIONS OF LIABILITY

The foregoing warranty is exclusive and in lieu of all other warranties and representations, whether expressed, implied, oral or written, including but not limited to any implied warranties or merchantability or fitness for a particular purpose. All such other warranties and representations are hereby cancelled.

Cla-Val shall not be liable for any incidental or consequential loss, damage or expense arising directly or indirectly from the use of the product. Cla-Val shall not be liable for any damages or charges for labor or expense in making repairs or adjustments to the product. Cla-Val shall not be liable for any damages or charges sustained in the adaptation or use of its engineering data and services. No representative of Cla-Val may change any of the foregoing or assume any additional liability or responsibility in connection with the product. The liability of Cla-Val is limited to material replacements F.O.B. Newport Beach, California.

TERMS OF SALE

ACCEPTANCE OF ORDERS

All orders are subject to acceptance by our main office at Newport Beach, California.

CREDIT TERMS

Credit terms are net thirty (30) days from date of invoice.

PURCHASE ORDER FORMS

Orders submitted on customer's own purchase order forms will be accepted only with the express understanding that no statements, clauses, or conditions contained in said order form will be binding on the Seller if they in any way modify the Seller's own terms and conditions of sales.

PRODUCT CHANGES

The right is reserved to make changes in pattern, design or materials when deemed necessary, without prior notice.

PRICES

All prices are F.O.B. Newport Beach, California unless expressly stated otherwise on our acknowledgement of the order. Prices are subject to change without notice. The prices at which any order is accepted are subject to adjustment to the Seller's price in effect at the time of shipment. Prices do not include sales, excise, municipal, state or any other Government taxes. Minimum order charge \$75.00.

RESPONSIBILITY

We will not be responsible for delays resulting from strikes, accidents, negligence of carriers, or other causes beyond our control. Also, we will not be liable for any unauthorized product alterations or charges accruing there from.

RISK

All goods are shipped at the risk of the purchaser after they have been delivered by us to the carrier. Claims for error, shortages, etc., must be made upon receipt of goods.

EXPORT SHIPMENTS

Export shipments are subject to an additional charge for export packing.

RETURNED GOODS

1. Customers must obtain written approval from Cla-Val prior to returning any material.
2. Cla-Val reserves the right to refuse the return of any products.
3. Products more than six (6) months old cannot be returned for credit.
4. Specially produced, non-standard models cannot be returned for credit.
5. Rubber goods such as diaphragms, discs, o-rings, etc., cannot be returned for credit, unless as part of an unopened vacuum sealed repair kit which is less than six months old.
6. Goods authorized for return are subject to a 35% (\$75 minimum) restocking charge and a service charge for inspection, reconditioning, replacement of rubber parts, retesting, repainting and repackaging as required.
7. Authorized returned goods must be packaged and shipped prepaid to Cla-Val, 1701 Placentia Avenue, Costa Mesa, California 92627.



CLA-VAL

PO Box 1325 Newport Beach CA 92659-0325
Phone: 949-722-4800 • Fax: 949-548-5441

CLA-VAL CANADA

4687 Christie Drive
Beamsville, Ontario
Canada LOR 1B4
Phone: 905-563-4963
Fax: 905-563-4040

CLA-VAL EUROPE

Chemin des Mésanges 1
CH-1032 Romanel/
Lausanne, Switzerland
Phone: 41-21-643-15-55
Fax: 41-21-643-15-50

COPYRIGHT CLA-VAL 2003 Printed in USA
Specifications subject to change without notice.

www.cla-val.com

Represented By:



— MODEL — **REPAIR KITS**

Complete Replacement Diaphragm Assemblies for 100-01 and 100-20 Hytrol Main Valves

For: Hytrol Main Valves with Ductile Iron, Bronze Trim Materials—125/150 Pressure Class Only.

FACTORY ASSEMBLED

Includes: Stem, Disc Guide, Disc, Disc Retainer, Spacer Washers, Diaphragm, Diaphragm Washer and Stem Nut.

Valve Size	Diaphragm Assembly Stock Number		Valve Size	Diaphragm Assembly Stock Number	
	100-01	100-20		100-01	100-20
3/8" (Also 81-01)	49097K	N/A	6"	40456G	33273E
1/2" - 3/4" (Also 81-01)	C2518D	N/A	8"	45276D	40456G
1"	C2520K	N/A	10"	81752J	45276D
1 1/4"-1 1/2"	C2522 F	N/A	12"	85533J	81752J
2"	C2524B	N/A	14"	89067D	N/A
2 1/2"	C2523D	N/A	16"	89068B	85533J
3"	C2525J	C2524B	20"	N/A	89068B
4"	33273E	C2525J	24"	N/A	89068B

Repair Kits for 100-01/100-20 Hytrol Valves

For: Hytrol Main Valves—125/150 Pressure Class Only.

Supplied Shrink Wrapped (4" and smaller) or Bagged (6" and larger)

Includes: Diaphragm, Disc (or Disc Assembly) and spare Spacer Washers.

Buna-N® Standard Material				Viton (For KB Valves)				
Valve Size	Repair Kit Stock Number		Valve Size	Repair Kit Stock Number		Valve Size	Repair Kit Stock Number	
	100-01	100-20		100-01	100-20		100-01	100-20
3/8" (Also 81-01)	9169801K	N/A	3/8" (Also 81-01)	9169806J	N/A	3/8" (Also 81-01)	9169806J	N/A
1/2" - 3/4" (Also 81-01)	9169802H	N/A	1/2" - 3/4" (Also 81-01)	9169807G	N/A	1/2" - 3/4" (Also 81-01)	9169807G	N/A
1"	9169803F	N/A	1"	9169808E	N/A	1"	9169808E	N/A
1 1/4" - 1 1/2"	9169804D	N/A	1 1/4" - 1 1/2"	9169809C	N/A	1 1/4" - 1 1/2"	9169809C	N/A
2"	9169805A	N/A	2"	9169810A	N/A	2"	9169810A	N/A
2 1/2"	9169811J	N/A	2 1/2"	9169817F	N/A	2 1/2"	9169817F	N/A
3"	9169812G	9169805A	3"	9169818D	9169810A	3"	9169818D	9169810A
4"	9169813E	9169812G	4"	9169819B	9169818D	4"	9169819B	9169818D
6"	9169815K	9169813E	6"	9169820K	9169819B	6"	9169820K	9169819B
8"	9817901D	9169815K	8"	N/A	9169820K	8"	N/A	9169820K
10"	9817902B	9817901D						
12"	9817903K	9817902B						
14"	9817904H	N/A						
16"	9817905E	9817903K						
20"	N/A	9817905E						
24"	N/A	9817905E						

When ordering, please give complete nameplate data of the valve and/or control being repaired.
MINIMUM ORDER CHARGE APPLIES.

Repair Kits for 100-02/100-21 Powertrol and 100-03/100-22 Powercheck Main Valves

For: Powertrol and Powercheck Main Valves—125/150 Pressure Class Only

Supplied Shrink Wrapped (4" and Smaller) or Bagged (6" and larger)

Includes: Diaphragm, Disc (or Disc Assembly) and spare Spacer Washers.

Valve Size	Kit Stock Number		Valve Size	Kit Stock Number	
	100-02			100-02 & 100-03	100-21 & 100-22
3/8"	9169901H		2 1/2"	9169910J	N/A
1/2" - 3/4"	9169902F		3"	9169911G	9169905J
1"	9169903D		4"	9169912E	9169911G
1 1/4" & 1 1/2"	9169904B		6"	9169913C	9169912E
2"	9169905J		8"	99116G	9169913C
			10"	N/A	99116G

Larger Sizes: Consult Factory.

Repair Kits for 100-04/100-23 Hy-Check Main Valves

For: Hy-Check Main Valves—125/150 Pressure Class Only

Supplied Shrink Wrapped (4" and Smaller) or Bagged (6" and larger)

Includes: Diaphragm, Disc and O-Rings and full set of spare Spacer Washers.

Valve Size	Kit Stock Number		Valve Size	Kit Stock Number	
	100-04	100-23		100-04	100-23
4"	20210901B	N/A	12"	20210905H	20210904J
6"	20210902A	20210901B	14"	20210906G	N/A
8"	20210903K	20210902A	16"	20210907F	20210905H
10"	20210904J	20210903K	20", 24"	N/A	20210907F

Larger Sizes: Consult Factory.

Repair Kits for Pilot Control Valves

Supplied Shrink Wrapped Includes: Diaphragm, Disc (or Disc Assembly), O-Rings, Gaskets or spare Screws as appropriate.

BUNA-N® (Standard Material)				VITON (For KB Controls)	
Pilot Control	Kit Stock Number	Pilot Control	Kit Stock Number	Pilot Control	Kit Stock Number
CDB	9170006C	CFM-7 & 7-A	1263901K	CDB-KB	9170012A
CDB-7	9170017K	CRA (w/bucking spring)	9170001D	CRA-KB	9170018H
CDH-2	18225D	CRD (w/bucking spring)	9170002B	CRD-KB (w/bucking spring)	9170008J
CDHS-2	44607A	CRD (no bucking spring)	9170003K	CRL-KB	9170013J
CDHS-2B	9170004H	CRD-22	98923G	CDHS-2BKB	9170010E
CDHS-2F	9170005E	CRL (55F, 55L)	9170007A	CDHS-2FKB	9170011C
CDHS-3C-A2	24657K	CRL-4A	43413E	CDHS-18KB (no bucking spring)	9170009G
CDHS-8A	2666901A	CRL-5 (55B)	65755B	102C-KB	1726202D
CDHS-18	9170003K	CRL-5A (55G)	20666E	Buna-N®	
CDS-4	9170014G	CV	9170019F	CRD DISC RET. (SOLID)	C5256H
CDS-5	14200A	X105L (O-ring)	00951E	CRD DISC RET. (SPRING)	C5255K
CDS-6	20119301A	102B-1	1502201F		
CFM-2, CFM-9, CFCM-M1	12223E	102C-2 & -3	1726201F		

Repair Assemblies (In Standard Materials Only)

Control	Description	Stock Number
CF1-C1	Pilot Assembly Only	89541H
CF1-CI	Complete Float Control less Ball & Rod	89016A
CFC2-C1	Disc, Distributor & Seals	2674701E
CSM 11-A2-2	Mechanical Parts Assy.	97544B
CSM 11-A2-2	Pilot Assembly Only	18053K
33A 1"	Complete Internal Assembly & Seal	2036030B
33A 2"	Complete Internal Assembly & Seal	2040830J

When ordering, please give complete nameplate data of the valve and/or control being repaired. MINIMUM ORDER CHARGE APPLIES