



— MODEL — **136-41**

Solenoid Control Valve Equipped for Dual Supply



- **Fast Acting Solenoid Control**
- **Drip Tight Shut-Off**
- **Simple Design, Proven Reliable**
- **Easy Installation & Maintenance**

The Cla-Val Model 136-41 Solenoid Control Valve is an on-off control valve which either opens fully or closes drip-tight upon receiving an electrical signal to the solenoid pilot control. This valve consists of a Hytrol main valve, a three way solenoid and a high capacity three-way pilot valve. The solenoid control operates the three-way valve which alternately applies pressure to or relieves pressure from the diaphragm chamber of the main valve. It is furnished either normally open (de-energize solenoid to open) or normally closed (energize solenoid to open).

Regardless of flow direction, the highest pressure is admitted into the main valve cover chamber and the valve closes to stop flow.

Schematic Diagram

Item	Description
1	100-01 Hytrol Main Valve
2	CS3 Solenoid Control
3	102C-3H Three-Way Valve
4	CVS-1 Shuttle Valve

Optional Features

Item	Description
A	X46 Flow Clean Strainer
B	CK2 Isolation Valve
C	CNA Needle Valve (Closing)
P	X141 Pressure Gauge
S	CNA Needle Valve (Opening)
V	X101 Valve Position Indicator
Y	X43 "Y" Strainer
KC	Epoxy Coating

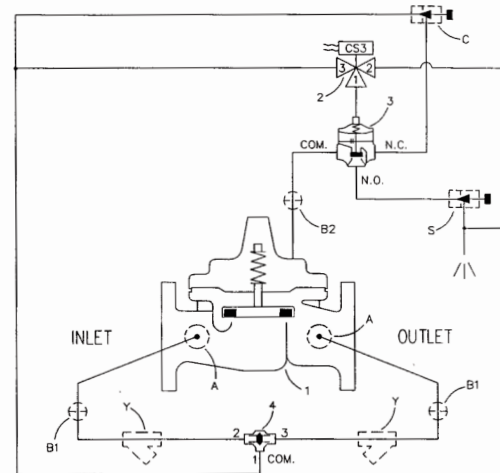

Typical Applications

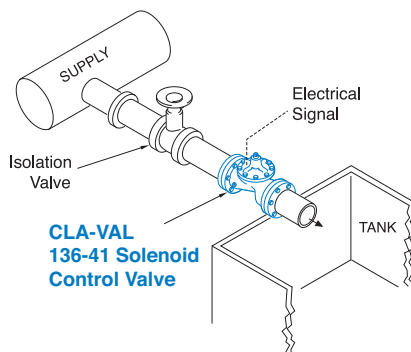

Industrial uses for the solenoid control valve are many and include accurate control of process water for batching, mixing, washing, blending or other on-off type uses.

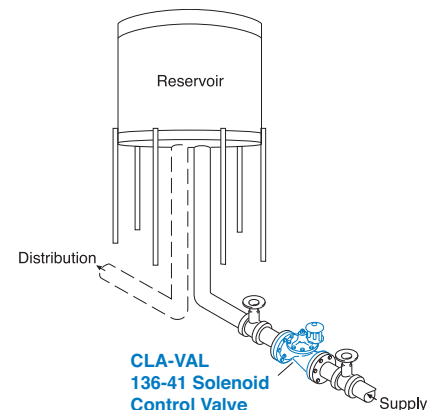

Liquid level control can be provided by using a level sensor or SCADA command which sends an electrical signal to open or close the valve as needed.

Model 136-41 (Uses 100-01 Hytrol Main Valve)

Pressure Ratings (Recommended Maximum Pressure - psi)

Valve Body & Cover		Pressure Class				
		Flanged		Grooved	Threaded	
Grade	Material	ANSI Standards*	150 Class	300 Class	300 Class	End‡ Details
ASTM A536	Ductile Iron	B16.42	250	400	400	400
ASTM A216-WCB	Cast Steel	B16.5	285	400	400	400
UNS 87850	Bronze	B16.24	225	400	400	400

Note: * ANSI standards are for flange dimensions only.
 Flanged valves are available faced but not drilled.
 ‡ End Details machined to ANSI B2.1 specifications.
Valves for higher pressure are available; consult factory for details

Materials

Component	Standard Material Combinations		
Body & Cover	Ductile Iron	Cast Steel	Bronze
Available Sizes (inches)	4" - 36"	4" - 16"	4" - 16"
Available Sizes (mm)	100 - 900 mm	100 - 400 mm	100 - 400 mm
Disc Retainer & Diaphragm Washer	Cast Iron	Cast Steel	Bronze
Trim: Disc Guide, Seat & Cover Bearing	Bronze is Standard Stainless Steel is Optional		
Disc	Buna-N® Rubber		
Diaphragm	Nylon Reinforced Buna-N® Rubber		
Stem, Nut & Spring	Stainless Steel		

For material options not listed, consult factory.
 Cla-Val manufactures valves in more than 50 different alloys.

Model 136-41 Dimensions (inches)

Valve Size (Inches)	4	6	8	10	12	14	16	18	20	24	30	36
A Threaded	—	—	—	—	—	—	—	—	—	—	—	—
AA 150 ANSI	15.00	20.00	25.38	29.75	34.00	39.00	41.38	46.00	52.00	61.50	63.00	72.75
AAA 300 ANSI	15.62	21.00	26.38	31.12	35.50	40.50	43.50	47.64	53.62	63.24	64.50	74.75
AAAA Grooved End	15.00	20.00	25.38	—	—	—	—	—	—	—	—	—
B Diameter	11.50	15.75	20.00	23.62	28.00	32.75	35.50	41.50	45.00	53.16	56.00	66.00
C Maximum	10.62	13.38	16.00	17.12	20.88	24.19	25.00	39.06	41.90	43.93	54.60	59.00
CC Maximum Grooved End	9.31	12.12	14.62	—	—	—	—	—	—	—	—	—
D Threaded	—	—	—	—	—	—	—	—	—	—	—	—
DD 150 ANSI	7.50	10.00	12.69	14.88	17.00	19.50	20.81	—	—	30.75	—	—
DDD 300 ANSI	7.88	10.50	13.25	15.56	17.75	20.25	21.62	—	—	31.62	—	—
DDDD Grooved End	7.50	—	—	—	—	—	—	—	—	—	—	—
E	3.19	4.31	5.31	9.25	10.75	12.62	15.50	12.95	15.00	17.75	21.31	24.56
EE Grooved End	4.25	6.00	7.56	—	—	—	—	—	—	—	—	—
F 150 ANSI	4.50	5.50	6.75	8.00	9.50	10.50	11.75	15.00	16.50	19.25	22.50	28.50
FF 300 ANSI	5.00	6.25	7.50	8.75	10.25	11.50	12.75	15.00	16.50	19.25	24.00	30.00
G Threaded	—	—	—	—	—	—	—	—	—	—	—	—
GG 150 ANSI	5.00	6.00	8.00	8.62	13.75	14.88	15.69	—	—	22.06	—	—
GGG 300 ANSI	5.31	6.50	8.50	9.31	14.50	15.62	16.50	—	—	22.90	—	—
GGGG Grooved End	5.00	—	—	—	—	—	—	—	—	—	—	—
H NPT Body Tapping	0.75	0.75	1.00	1.00	1.00	1.00	1.00	1.00	1.00	1.00	2.00	2.00
J NPT Cover Center Plug	0.75	0.75	1.00	1.00	1.25	1.50	2.00	1.00	1.00	1.00	2.00	2.00
K NPT Cover Tapping	0.75	0.75	1.00	1.00	1.00	1.00	1.00	1.00	1.00	1.00	2.00	2.00
Stem Travel	1.10	1.70	2.30	2.80	3.40	4.00	4.50	5.10	5.63	6.75	7.50	8.50
Approx. Ship Weight (lbs)	140	285	500	780	1165	1600	2265	2982	3900	6200	7703	11720
Approx. X Pilot System	17	29	31	33	36	40	40	43	47	68	79	85
Approx. Y Pilot System	12	20	22	24	26	29	30	32	34	39	40	45
Approx. Z Pilot System	12	20	22	24	26	29	30	32	34	39	42	47

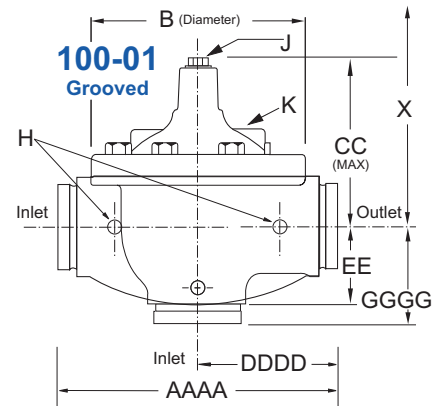
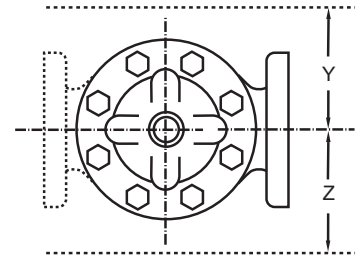
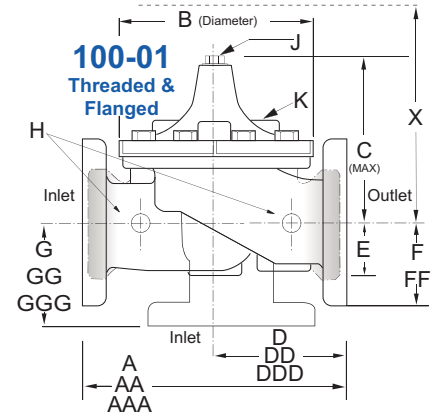

Model 136-41 Metric Dimensions (Uses 100-01 Hytrol Main Valve)

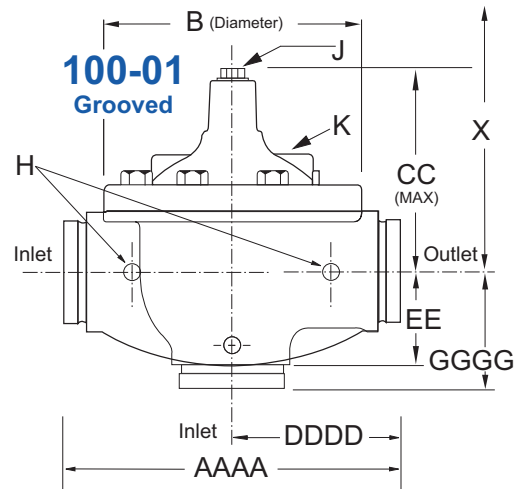
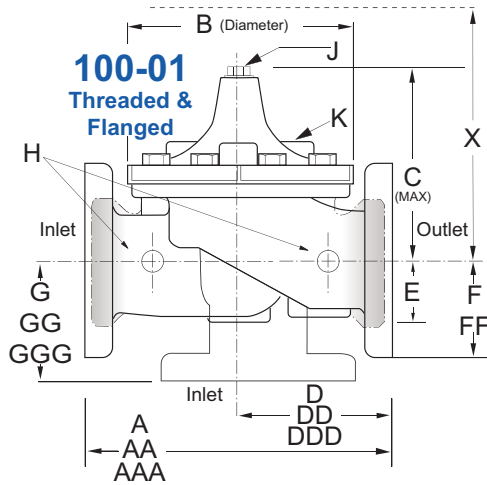
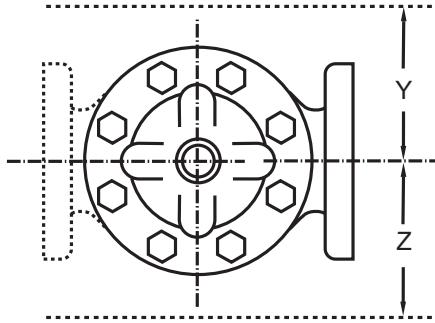

Model 136-41 Dimensions (mm)

Valve Size (mm)	100	150	200	250	300	350	400	450	500	600	750	900
A Threaded	—	—	—	—	—	—	—	—	—	—	—	—
AA 150 ANSI	381	508	645	756	864	991	1051	1168	1321	1562	1600	1848
AAA 300 ANSI	397	533	670	790	902	1029	1105	1210	1326	1606	1638	1899
AAAA Grooved End	381	508	645	—	—	—	—	—	—	—	—	—
B Diameter	292	400	508	600	711	832	902	1054	1143	1350	1422	1676
C Maximum	270	340	406	435	530	614	635	992	1064	1116	1387	1499
CC Maximum Grooved End	236	308	371	—	—	—	—	—	—	—	—	—
D Threaded	—	—	—	—	—	—	—	—	—	—	—	—
DD 150 ANSI	191	254	322	378	432	495	528	—	—	781	—	—
DDD 300 ANSI	200	267	337	395	451	514	549	—	—	803	—	—
DDDD Grooved End	191	—	—	—	—	—	—	—	—	—	—	—
E	81	110	135	235	273	321	394	329	381	451	541	624
EE Grooved End	108	152	192	—	—	—	—	—	—	—	—	—
F 150 ANSI	114	140	171	203	241	267	298	381	419	489	572	724
FF 300 ANSI	127	159	191	222	260	292	324	381	419	489	610	762
G Threaded	—	—	—	—	—	—	—	—	—	—	—	—
GG 150 ANSI	127	152	203	219	349	378	399	—	—	560	—	—
GGG 300 ANSI	135	165	216	236	368	397	419	—	—	582	—	—
GGGG Grooved End	127	—	—	—	—	—	—	—	—	—	—	—
H NPT Body Tapping	0.75	0.75	1.00	1.00	1.00	1.00	1.00	1.00	1.00	1.00	2.00	2.00
J NPT Cover Center Plug	0.75	0.75	1.00	1.00	1.25	1.50	2.00	1.00	1.00	1.00	2.00	2.00
K NPT Cover Tapping	0.75	0.75	1.00	1.00	1.00	1.00	1.00	1.00	1.00	1.00	2.00	2.00
Stem Travel	28	43	58	71	86	102	114	130	143	171	190	216
Approx. Ship Weight (kgs)	64	129	227	354	528	726	1027	1353	1769	2812	3494	5316
Approx. X Pilot System	432	737	788	839	915	1016	1016	1093	1194	1728	2007	2159
Approx. Y Pilot System	305	508	559	610	661	737	762	813	864	991	1016	1143
Approx. Z Pilot System	305	508	559	610	661	737	762	813	864	991	1067	1194

136-41 Valve Selection	100-01 Pattern: Globe (G), Angle (A), End Connections: Threaded (T), Grooved (GR), Flanged (F) Indicate Available Sizes												
	Inches	4	6	8	10	12	14	16	18	20	24	30	36
	mm	100	150	200	250	300	350	400	450	500	600	750	900
Main Valve 100-01	Pattern	G, A	G, A	G, A	G, A	G, A	G, A	G, A	G	G	G, A	G	G
	End Detail	F, Gr	F, Gr*	F, Gr*	F	F	F	F	F	F	F	F	F
Suggested Flow (gpm)	Maximum	800	1800	3100	4900	7000	8400	11000	14000	17000	25000	42000	50000
	Maximum Intermittent	990	2250	3900	6150	8720	10540	13700	17500	21700	31300	48000	62500
Suggested Flow (Liters/Sec)	Maximum	50	113	195	309	442	530	694	883	1073	1577	2650	3150
	Maximum Intermittent	62	142	246	387	549	664	863	1104	1369	1972	3028	3940

100-01 Series is the full internal port Hytrol. *Globe Grooved Only

Pilot System Specifications

Temperature Range

Water: to 180°F/82°C

Fluids

Air, water, light oils

Solenoid Control

Body:

Brass ASTM B283

Rubber Parts:

Buna-N® Synthetic Rubber

Enclosure:

NEMA Type 1,2,3,3S,4,4X general purpose watertight*

NEMA Type 6,6P,7,9 watertight Explosion Proof available.

Voltages:

110, 220 - 50Hz AC

24, 120, 240, 480 - 60Hz AC

6, 12, 24, 120, 240 - DC

Others available at additional cost

Max. operating pressure differential: 200 psi*

Coil:

Insulation molded Class	F
Watts AC	6
AC Volt Amps Inrush	30
AC Volt Amps Holding	16
Watts DC	10.6

Manual operator available at additional cost.

*Supplied unless otherwise specified

Note: Flowing Pressure Differential: 5 psi minimum

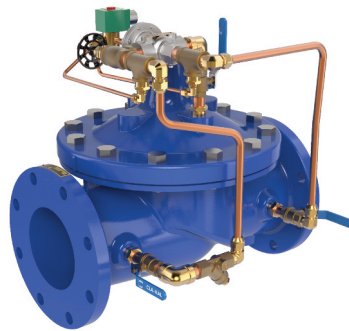

Valve Options

X141 Pressure Gauge



X101AR Valve Position Indicator with Air Release



X101 Valve Position Indicator



X144 e-FlowMeter



X43H Strainer



Stainless Steel Pilot



When Ordering, Specify

- Catalog No. 136-41
- Valve Size
- Pattern - Globe or Angle
- Pressure Class
- Threaded or Flanged
- Materials Desired
- Energized or de-energized to open Main Valve
- Solenoid Enclosure, Voltage & Hertz, Coil Insulation, and Max. Operating Pressure Differential
- Desired Options
- When Vertically Installed