



— MODEL — **134-83**

# Solenoid Operated and Pressure Reducing Control Deluge Valve



134G-83



- U.L. Listed / U.L.C. Listed
- Fast Acting Solenoid Control
- Reliable Drip Tight Shut-off
- Simple Design, Proven Reliable
- Easy Installation & Maintenance
- Precise Downstream Pressure Control

The Cla-Val Model 134-83 Solenoid Operated and Pressure Reducing Control Deluge Valve is an on-off control valve that either opens or closes upon receiving an electrical signal to the solenoid pilot control as well as regulates downstream pressure using the CRD Pressure Reducing Pilot. This valve consists of U.L. listed 100GS/2100GS hytrol main valve, a three-way solenoid valve and an auxiliary pilot valve and the CRD Pressure Reducing Pilot Control. This pilot control system alternately applies pressure to/or relieves pressure from the diaphragm chamber of the main valve. It is furnished either normally open (de-energize solenoid to open) or normally closed (energized solenoid to open).

## Schematic Diagram

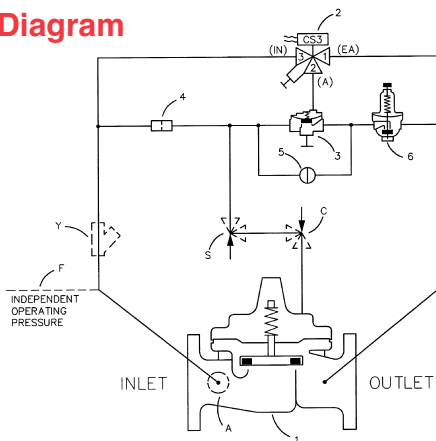

## Item Description

- |   |                                     |
|---|-------------------------------------|
| 1 | 100GS/2100GS Hytrol Main Valve      |
| 2 | CS3XM Solenoid Control              |
| 3 | 100-01 Auxiliary Hytrol             |
| 4 | X58C Restriction Assembly           |
| 5 | CK2 Cock (Solenoid Bypass)          |
| 6 | CRD Pressure Reducing Pilot Control |

## Specification

**SIZES** Globe: 1 1/2" -10"  
Angle: 1 1/2" -10"

**END DETAILS** Ductile Iron 150 ANSI B16.42 flanged  
Cast Steel 150 ANSI B16.5 flanged

**PRESSURE RATINGS** 150 class, 250 psi maximum (Ductile Iron)  
150 class, 285 psi maximum (Cast Steel)  
300 class, 400 psi maximum

**TEMPERATURE RANGE** Water: to 180° F. Max

**CRD SPRING RANGE** 15 - 75 psi • 30 - 300 psi

Functional Data **Now available in sizes 1 1/2" - 10"**

Valve Size		Inches	3	4	6	8	10
		mm	80	100	150	200	250
Cv Factor	Globe Pattern	Gal./Min. (gpm.)	115	200	440	770	1245
		Litres/Sec. (L/s)	27.6	48	105.6	184.8	299
	Angle Pattern	Gal./Min. (gpm.)	139	240	541	990	1575
		Litres/Sec. (L/s)	33.4	58	130	238	378

## MATERIALS

### Main valve body & cover

Ductile Iron ASTM A-536\*  
Cast Steel ASTM A216-WCB\*  
Naval Bronze ASTM B61  
Nickel Aluminum Bronze ASTM B148 C95800  
Super Duplex Stainless Steel ASTM A890 GR5A  
Stainless Steel ASTM A743-CF-8M

### Main valve trim:

Bronze / Monel

### Tubeing & Fittings

316 SST, Monel, or 2507 SDS

### Pilot control system:

Cast Bronze ASTM B61  
UL Listed 3" - 10"

## Cover Capacity

Valve Size	Displacement
3"	.080 gal
4"	.169 gal
6"	.531 gal
8"	1.26 gal
10"	2.51 gal



100GS (Globe)

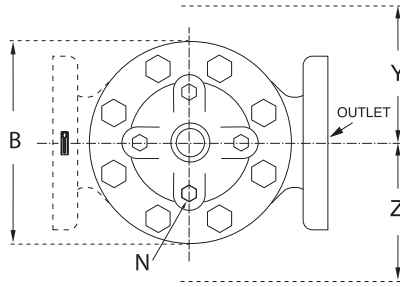
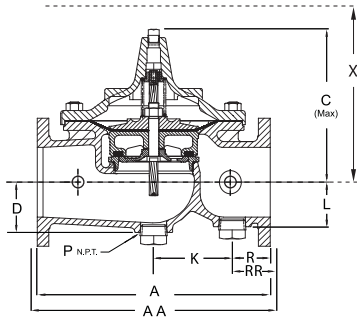

2100GS (Angle)

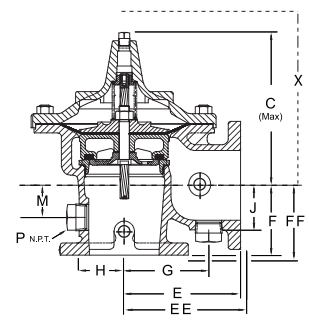

Valve Size (in)	3	4	6	8	10
A 150 ANSI	12.00	15.00	20.00	25.38	29.75
AA 300 ANSI	13.25	15.62	21.00	26.38	31.12
B Dia.	9.12	11.50	15.75	20.00	23.62
C Max.	8.19	10.62	13.28	16.00	17.12
D	2.56	3.19	4.31	5.16	8.50
E 150 ANSI	7.00	8.50	10.00	12.69	14.88
EE 300 ANSI	--	8.81	10.50	13.19	--
F 150 ANSI	4.00	4.97	6.00	8.00	8.62
FF 300 ANSI	--	5.28	6.50	8.50	--
G	4.75	5.94	7.25	8.50	10.50
H	2.69	2.81	3.88	5.31	6.56
J	2.56	2.81	3.81	4.81	5.81
K	7.00	4.03	6.75	17.00	15.50
L	2.56	2.81	3.81	4.81	8.50
M	1.75	2.41	2.75	4.00	4.24
N NPT	1/2"-14	3/4"-14	3/4"-14	1"-11 1/2	1"-11 1/2
P NPT	1-1/4"-11 1/2"	2"-11 1/1/2"			
R 150 ANSI	2.50	3.47	3.25	4.19	7.12
RR 150 ANSI	3.12	3.78	3.75	4.69	7.81
X Pilot System	15.00	17.00	29.00	31.00	33.00
Y Pilot System	11.00	12.00	20.00	22.00	24.00
Z Pilot System	11.00	12.00	20.00	22.00	24.00

Valve Size (mm)	80	100	150	200	250
A 150 ANSI	305	381	508	645	756
AA 300 ANSI	337	397	533	670	791
B Dia.	232	292	400	508	600
C Max.	208	270	340	406	435
D	65	81	110	131	216
E 150 ANSI	178	216	254	322	378
EE 300 ANSI	--	224	267	350	--
F 150 ANSI	102	126	152	203	219
FF 300 ANSI	--	134	165	216	--
G	121	151	184	216	267
H	68	71	99	135	167
J	65	71	97	122	148
K	178	102	171	432	394
L	65	71	97	122	216
M	45	61	70	102	108
N NPT	1/2"-14	3/4"-14	3/4"-14	1"-11 1/2	1"-11 1/2
P NPT	1-1/4"-11 1/2"	2"-11 1/1/2"			
R 150 ANSI	64	88	83	106	181
RR 150 ANSI	79	96	95	119	198
X Pilot System	381	432	737	787	838
Y Pilot System	279	305	508	559	610
Z Pilot System	279	305	508	559	610

**Pilot System Specifications**

**Temperature Range**

Water: to 180°F

**Fluids**

Air, water, light oils

**Rubber Parts**

Buna-N® Synthetic Rubber

**Solenoid Control\***

Body:

Brass ASTM B283

Enclosure:

NEMA Type 1, 2, 3, 3S, 4, 4X general purpose watertight

NEMA Type 6, 6P, 7, 9 watertight

Explosion Proof available at extra cost

**Voltages:**

110, 220 -50Hz AC

24, 120, 240, 480 -60Hz AC

6, 12, 24, 120, 240 - DC

Others available at extra cost

Max. operating pressure differential: 200 psi

Coil:

Insulation Molded Class F

Watts AC 6

AC Volt Amps Inrush 30

AC Volt Amps Holding 16

Watts DC 10.6

Manual operator available at extra cost.

UL Listed: 3" - 10"

\*Optional material available for Seawater Service

**When Ordering, Please Specify**

1. Catalog No. 134-83
2. Valve Size
3. Pattern - Globe or Angle
4. Pressure Class
5. Threaded, Flanged or Grooved
6. Material Desired
7. Energized or De-energized to Open Main Valve
8. Solenoid Enclosure, Voltage & Hertz
9. When Vertically Installed



**CLA-VAL**

PO Box 1325 Newport Beach CA 92659-0325

800-942-6326 • Fax: 949-548-5441 • Web Site: cla-val.com • E-mail: claval@cla-val.com

**CLA-VAL CANADA**

4687 Christie Drive  
Beamsville, Ontario  
Canada L0R 1B4  
Phone: 905-563-4963  
Fax: 905-563-4040  
E-mail sales@cla-val.ca

**CLA-VAL EUROPE**

Chemin des Mésanges 1  
CH-1032 Romanel/  
Lausanne, Switzerland  
Phone: 41-21-643-15-55  
Fax: 41-21-643-15-50  
E-mail: cla-val@cla-val.ch

**CLA-VAL UK**

Dainton House, Goods Station Road  
Tunbridge Wells  
Kent TN1 2 DH England  
Phone: 44-1892-514-400  
Fax: 44-1892-543-423  
E-mail: info@cla-val.co.uk

**CLA-VAL FRANCE**

Porte du Grand Lyon 1  
ZAC du Champ du Périer  
France - 01700 Neyron  
Phone: 33-4-72-25-92-93  
Fax: 33-4-72-25-04-17  
E-mail: cla-val@cla-val.fr

**CLA-VAL PACIFIC**

45 Kennaway Road  
Woolston, Christchurch, 8023  
New Zealand  
Phone: 64-39644860  
Fax: 64-39644786  
E-mail: gnuthall@cla-val.com