

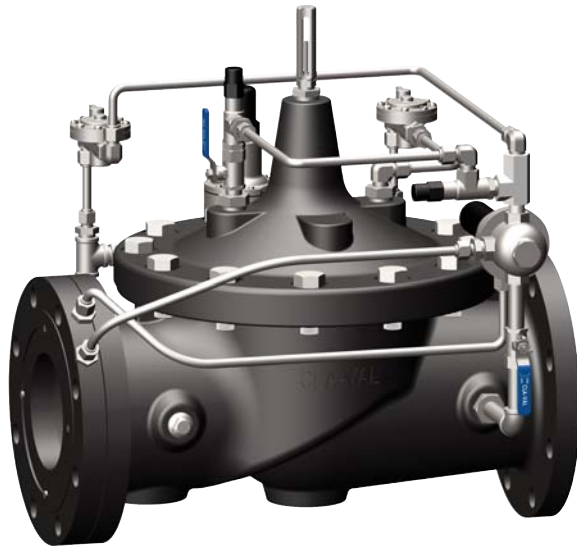

— MODEL — **40-30**

Non-Surge Check Valve with Flow Limiting Features



- Protects pumps against reverse flow
- Surge-free operation
- Adjustable opening and closing rates
- Fail-safe operation
- Limits flow to a pre-set maximum
- Factory sized for proper performance
- Available in aluminum, cast steel, stainless steel or ductile iron

The Model 100-34 Hytrol Valve is used as the basic unit in almost all Cla-Val automatic control valves for petroleum applications. The 100-34 is a hydraulically-operated, diaphragm actuated, globe or angle pattern valve. It is available in various materials and full range of sizes. It consists of three major components: body, diaphragm assembly and cover. The diaphragm assembly is the only moving part. The rugged simplicity of design and packless construction assure a long life dependable, trouble-free operation. Should the diaphragm become damaged the valve will close tight, providing "fail safe" operation. The 100-34 Hytrol Valve is used in many types of piping system requiring control, flow regulation, rate of flow control, or check valve operation.

Schematic Diagram

Item	Description
1	100-34 Hytrol (Reverse Flow)
2	X47A Ejector
3	CDHS2B Pressure Differential Control
4	X101 Valve Position Indicator
5	X52B Orifice Plate Assembly

Optional Features

Item	Description
A	X46A Flow Clean Strainer
B	CK2 Cocks (Isolation Valve)
C	CV Flow Control (Closing)
G	81-01 Check Valve w/ Cock
Q	Quick Connect Assembly
S	CV Flow Control (Opening)
T	55F Thermal Relief Control
Y	X43 "Y" Strainer

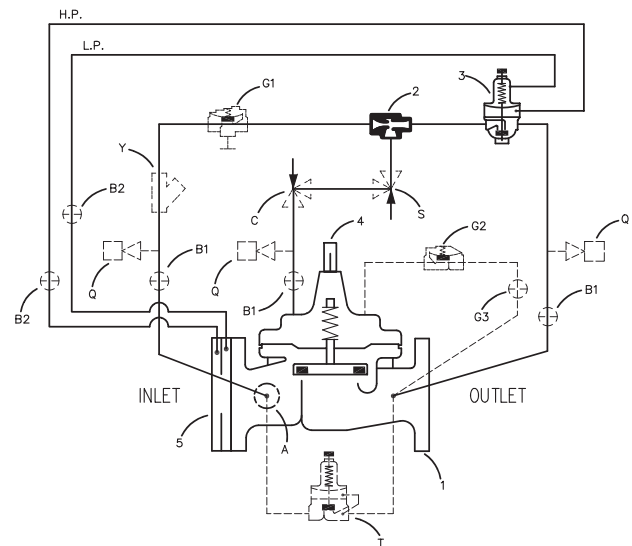

Specifications

Sizes

Globe: 1 1/2" - 16" flanged
Angle: 2" - 16" flanged

End Details

Flanged:

Cast Aluminum, 150 ANSI B16.1
Cast Bronze, 150 & 300 ANSI B16.24
Ductile Iron, 150 & 300 ANSI B16.42
Cast Steel, 150 & 300 ANSI B16.5

Temperature Range

Light Petroleum Product -40° to +140°F

Pressure Ratings

150 class 175-PSI Max
150 class 275-PSI Max
250 class 300-PSI Max
300 class 400-PSI Max

Material

Body & cover:
Cast Aluminum, 356-T6
Cast Bronze ASTM B62
Ductile Iron ASTM A-536
Cast Stainless Steel 303
Cast Steel ASTM A216-WCB

Valve trim:

Bronze ASTM B61
Stainless Steel 303

Rubber parts:

Buna-N® Synthetic Rubber
Viton

Other Materials

Available on Special Order



Principle of Operation

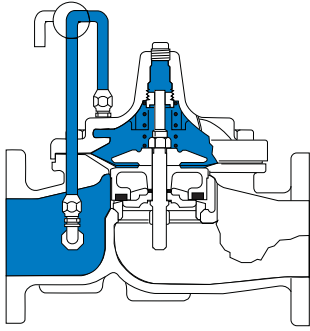

Tight Closing Operation

When pressure from the valve inlet (or an equivalent independent operating pressure) is applied to the diaphragm chamber, the valve closes drip-tight.

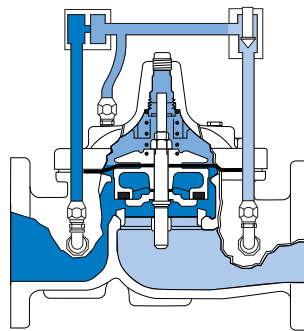

Full Open Operation

When pressure in the diaphragm chamber is relieved to zone of lower pressure under the valve. Flow in either direction is permitted.

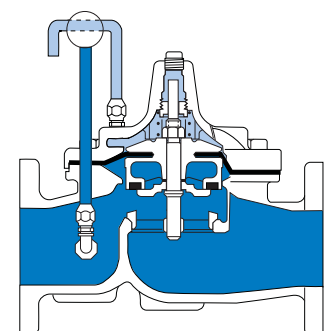

Modulating Action

The valve modulates when diaphragm chamber pressure is held at an intermediate point between inlet and discharge pressure changes, the pressure above the diaphragm is varied allowing the valve to modulate and compensate for the changes.

SIZE	1 1/2	2	2 1/2	3	4	6	8	10	12	14	16
A 125 & 150 ANSI	8.50	9.38	11.00	12.00	15.00	20.00	25.38	29.75	34.00	39.00	41.38
AA 250 & 300 ANSI	9.00	10.00	11.62	13.25	15.62	21.00	26.38	31.12	35.50	40.50	43.50
B DIAMETER	5.62	6.62	8.00	9.12	11.50	15.75	20.00	23.62	28.00	32.75	35.50
C MAX.	5.50	6.50	7.56	8.19	10.62	13.38	16.00	17.12	20.88	24.19	25.00
D	1.12	1.50	1.69	2.06	3.19	4.31	5.31	9.25	10.75	12.62	15.50
E 125 & 150 ANSI	-	4.75	5.00	6.00	7.50	10.00	12.75	14.88	17.00	19.50	20.81
EE 250 & 150 ANSI	-	5.00	5.88	6.38	7.88	10.50	13.25	15.56	17.75	20.25	21.62
F 125 & 150 ANSI	-	3.25	4.00	4.00	5.00	6.00	8.00	8.62	13.75	14.88	15.69
FF 250 & 300 ANSI	-	3.50	4.31	4.38	5.31	6.50	8.50	9.31	14.50	15.62	16.50

CV Factor

Valve Size	1 1/2	2	2 1/2	3	4	6	8	10	12
100-34 GLOBE PATTERN	26	49	80	107	200	440	771	1151	1600
100-34 ANGLE PATTERN	30	62	100	137	-	-	-	-	-

CV factor is defined as the number of gallons per minute of water at 60°F. Which will flow at a 60°F. Which will flow at a one pound per square inch differential.

Purchase Specifications

The valve shall be hydraulically-operated, diaphragm-actuated, globe or angle pattern valve. It shall contain a resilient, synthetic rubber disc, having a rectangular cross section, contains on three and one-half sides by a disc retainer and disc guide, forming a tight seal against a single renewable seat. The valve stem shall be guided at both ends by a bearing in the valve cover and an integral bearing in the valve seat. The diaphragm assembly shall be the only moving part and shall form a sealed chamber in the upper portion of the valve, separating operating pressure from line pressure. The diaphragm consist of nylon fabric bonded with synthetic rubber and shall not be used as a seating surface. Packing glands and/or stuffing boxes are not permitted and there shall be no pistons operating the valve. All necessary repairs shall be possible without removing the valve from the line. If the diaphragm becomes damaged the valve shall close tight. This valve shall be a Model 100-34 (globe pattern or angle pattern) Hytrol Valve as manufactured by Cla-Val. Newport Beach, California.

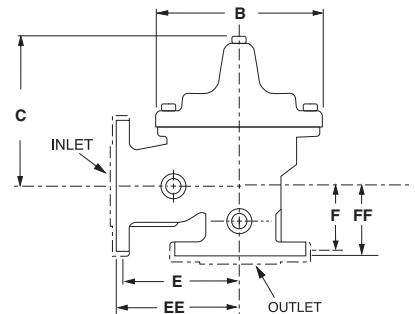
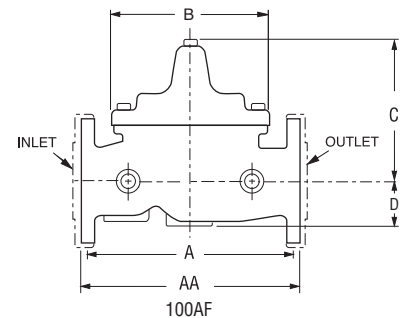

Specify When Ordering

1. Size
2. Model 40-30 Globe or Angle
3. Pressure Class
4. Temperature and fluid to be handled
5. Static and flowing line pressure
6. Operating fluid and pressure (if other than line pressure)
7. Body and trim materials
8. End details

