



# Flanged Float Control



- **Completely automatic operation**
- **No lubrication required**
- **No adjustments required**
- **Compact and easy to install**
- **Built-in float ball and control tester**
- **Conforms to rigid military specifications**

The Cla-Val Model CFF21 Flanged Float Control is a float operated pilot control installed in the water accumulation sump of a fuel filter/separator. It is designed to automatically actuate a water drain valve (Model 100AF) and to sense a rapid accumulation of water in the sump in excess of the capacity of the drain valve. If the water level cannot be reduced by the drain valve, the float control signals the fuel discharge valve to close until the water has been drained.

The Model CFF21 Flanged Float Control features an integral tester which allows in-service testing of the pilot operation and the integrity of the float ball. Conventional testers only test the operation of the control pilot mechanism, they do not check the integrity of the float ball itself. A simple ballasting method is used in the Model CFF21 making it possible to test the operation of the control pilot and to determine if the float is sound and buoyant without the costly and time consuming process of removing the control from the separator or injecting water into the sump.

## SPECIFICATIONS

MIL-F-8901, MIL-F-15618,  
MIL-F-52694C and MIL-F-  
27629D (USAF)

-40°F to 180°F

*Light petroleum products; M 1 L-G  
-5572, M 1 L- T -5624L and MIL-T-  
83133A*

Aluminum - 7 lbs.

Stainless - 14 lbs.

225 PSI

*Flange and Pilot Housing:*

Stainless Steel ASTM A 296

Aluminum 356T6

*Pilot Valve:*

Stainless Steel 303

*Float Ball & arm:*

Stainless Steel 303

## Purchase Specifications

This control shall be specifically designed to respond to changes in level of the interface surface of the water and fuel inside the water sump and shall operate the diaphragm actuated water drain valve and fuel discharge valve. The actuating fluids on the diaphragms of both the water drain valve and the fuel discharge valve shall be relieved through the pilot valve to the outlet of the water drain valve.

The float control shall consist of a mounting flange with integral pilot valve and float ball assembly. By actuation of an external lever the float ball ballast may be removed.

This action permits the float to rise in fuel verifying its buoyancy. The pilot shall be a precision-lapped, rotary disc plate type valve. Porting arrangement shall permit control of a water drain valve and a fuel discharge valve.

This control shall be the Model

CFF21 Flanged Float Control as manufactured by Cla-Val Newport Beach, California.

## Integral Tester Feature (Patent Pending)

In normal operating position (1) the float ball ballast is fixed to the float for automatic water level control. Removing the ballast from the float (2) allows the float ball to float in fuel (3 & 4). The sequential operation of the water drain valve and the fuel discharge valve verifies the integrity of the float ball and the proper functioning of the pilot control mechanism. This unique approach is, the only positive means of totally checking the control function while the filter/separator is in service.

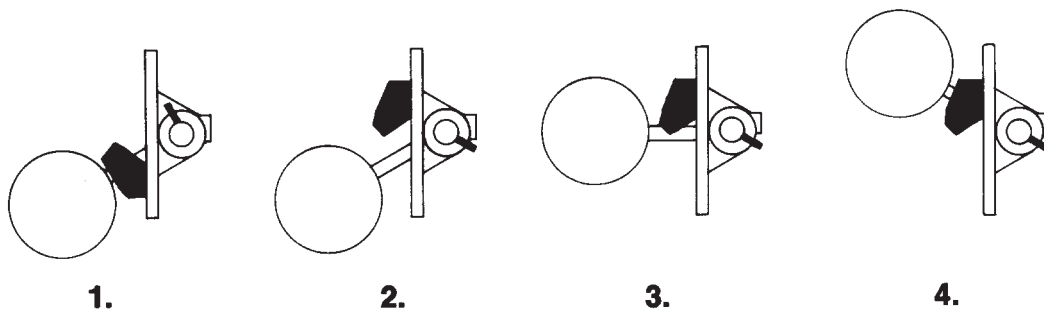

## Dimensions (in inches)

8 holes 1/2" diam.  
spaced on 6.625 BCD

### Note:

Float Ball and Arm Dimensions will increase if operating pressure exceeds 225psi and/or specific gravity of fuel is greater than .8 (consult factory).

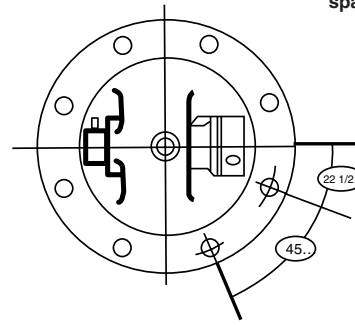
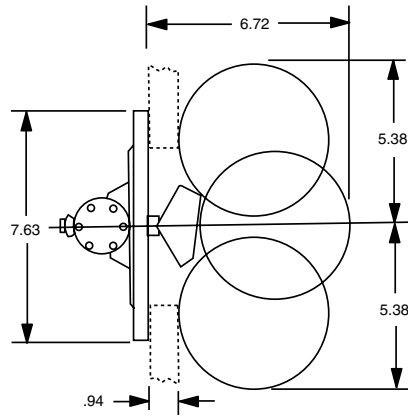

1. Flange and Pilot Materials
2. Specific Gravity of fuel
3. Operating Pressure

## Typical Applications

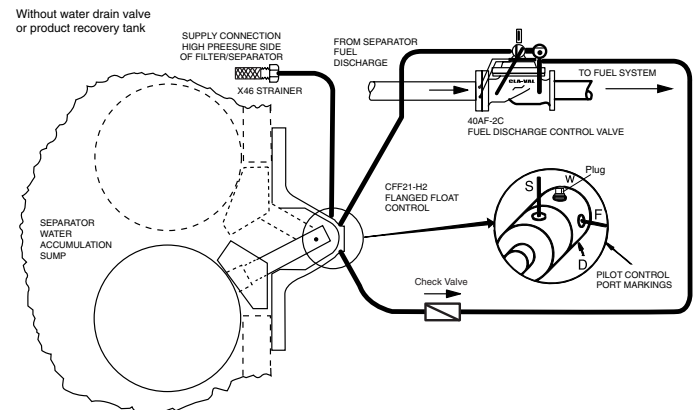
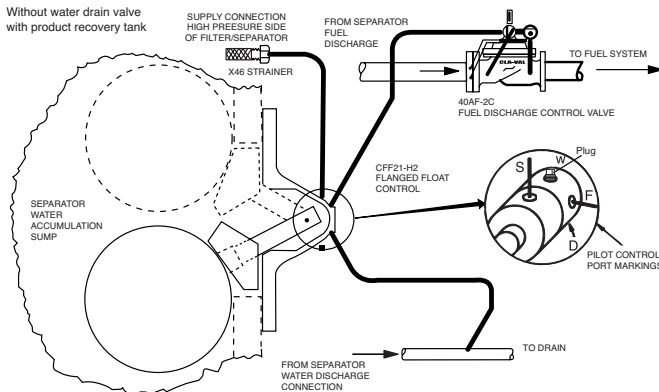
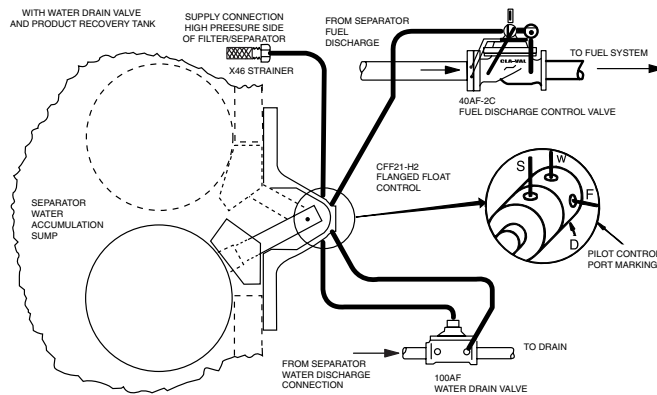

E-CFF21 (R-3/09)

## CLA-VAL

PO Box 1325 Newport Beach CA 92659-0325  
Phone: 949-722-4800 • Fax: 949-548-5441

### CLA-VAL CANADA

4687 Christie Drive  
Beamsville, Ontario  
Canada L0R 1B4  
Phone: 905-563-4963  
Fax: 905-563-4040

### CLA-VAL EUROPE

Chemin des Mesanges 1  
CH-1032 Romanel/  
Lausanne, Switzerland  
Phone: 41-21-643-15-55  
Fax: 41-21-643-15-50

©COPYRIGHT CLA-VAL 2009 Printed in USA  
Specifications subject to change without notice.

www.cla-val.com

Represented By: